

SPECIFICATION:

JOSAM 17100-M1568 FLOOR MOUNTED SINGLE CARRIER WITH CONCEALED ARMS, LUG SECURING BOLTS, STRUCTURAL UPRIGHTS FOR CAST IRON FIXTURES WITH SECURING LUGS. DESIGNED TO SUPPORT CECO 551A, 553, AND ZURN Z5840 LAVATORIES.

**LAVATORY CARRIER
SPECIAL**

SERIES **17100-M1568**

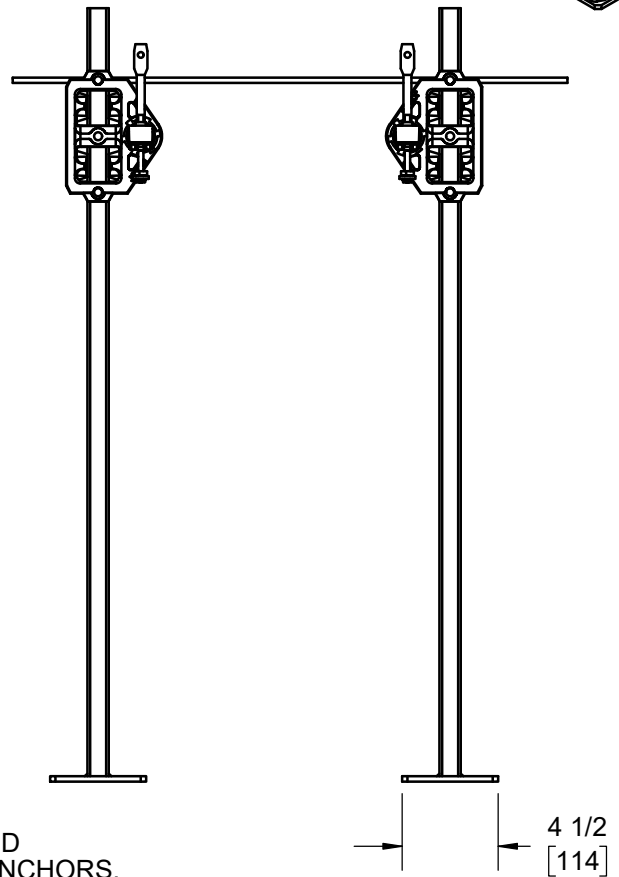
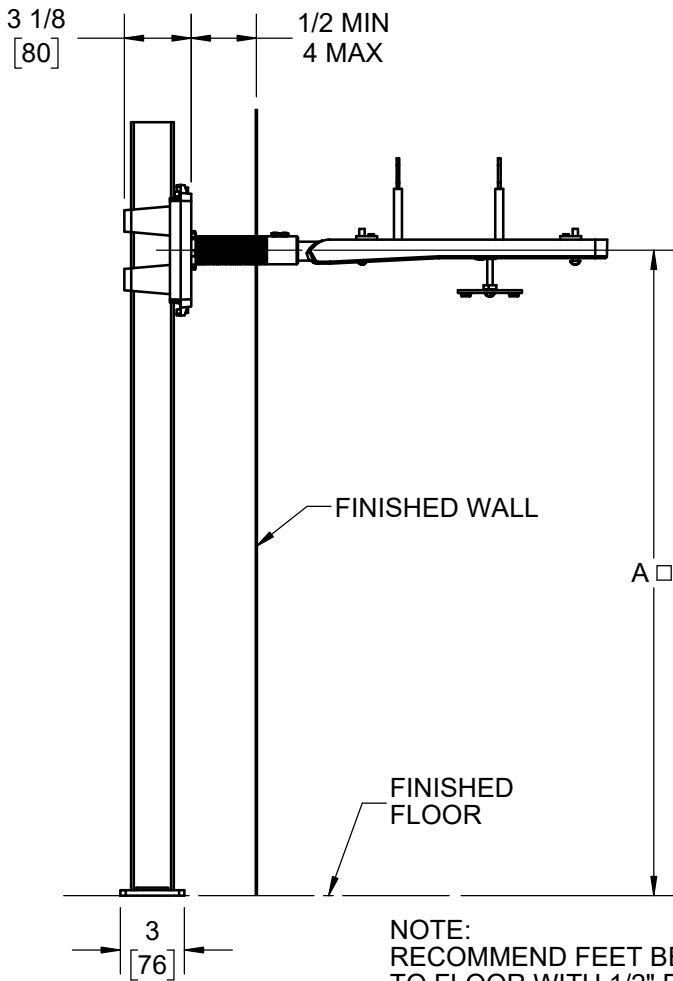
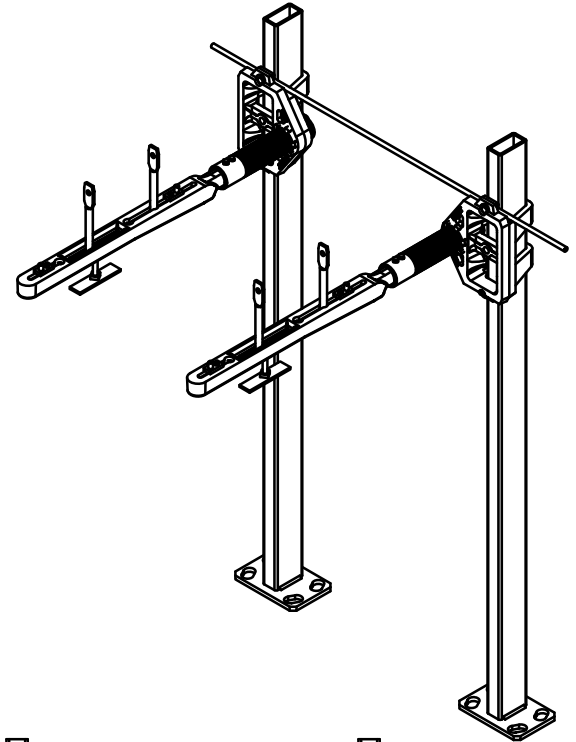
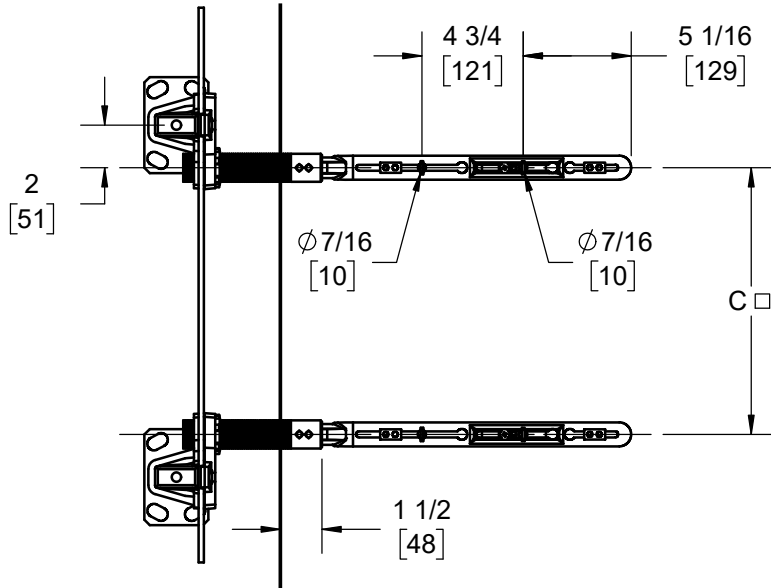

NOTE:
RECOMMEND FEET BE SECURED
TO FLOOR WITH 1/2" BOLTS & ANCHORS,
BY OTHERS

WARNING: Cancer and Reproductive Harm - www.P65Warnings.ca.gov

DATE OF LAST CHANGE: 05/16/22

DIMENSIONS ARE SUBJECT TO MANUFACTURERS TOLERANCES AND CHANGE WITHOUT NOTICE. WE CAN ASSUME NO RESPONSIBILITY FOR USE OF SUPERSEDED OR VOID DATA.

JOSAM
MICHIGAN CITY, INDIANA

NOTES