

SPECIFICATION:

JOSAM 60610A-EXT SERIES EPOXY COATED FABRICATED STEEL OIL SEPARATOR, HIGH-VOLUME, DEEP ROUGHING, INTEGRAL EXTENSION, THREADED CONNECTIONS, VISIBLE DOUBLE WALL TRAP AND SEDIMENT BUCKET, ADJUSTABLE GRAVITY DRAW-OFF EITHER SIDE, TWO VENT CONNECTIONS ON EACH SIDE, GASKETED NON-SKID COVER AND FLOW-CONTROL FITTING.

**OIL SEPARATOR
DRAW-OFF,
HIGH-VOLUME TYPE**

SERIES **60610A-EXT**

FORMERLY 60600A SERIES

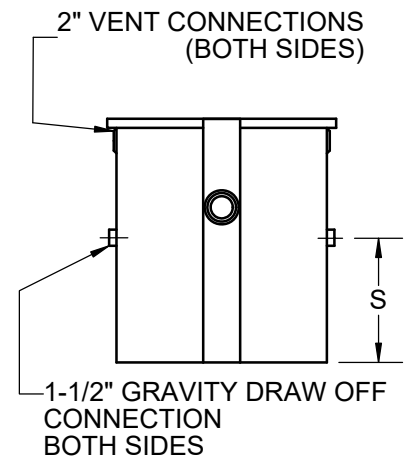
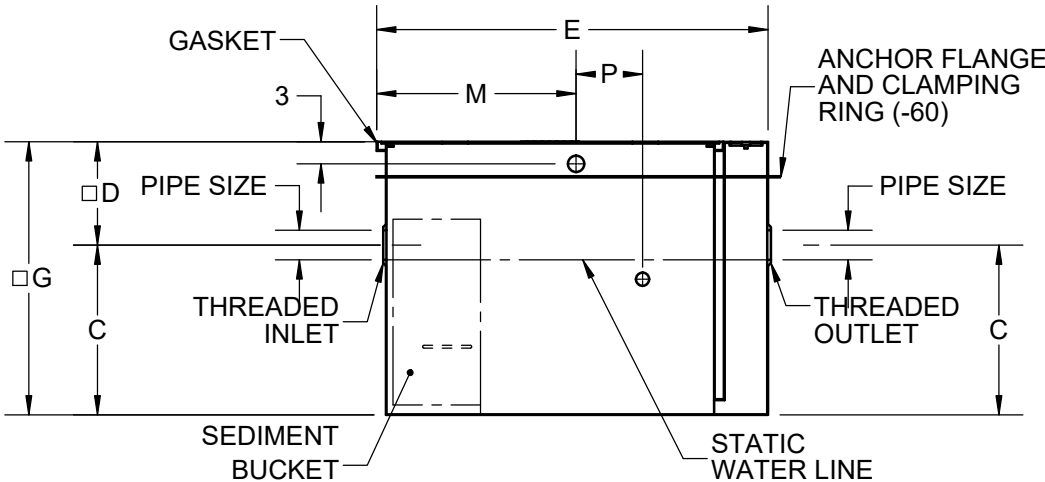
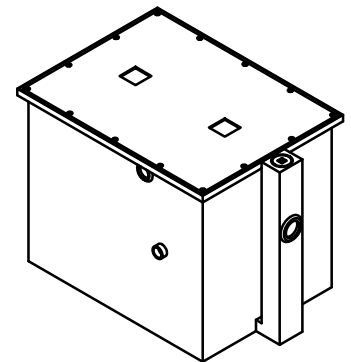
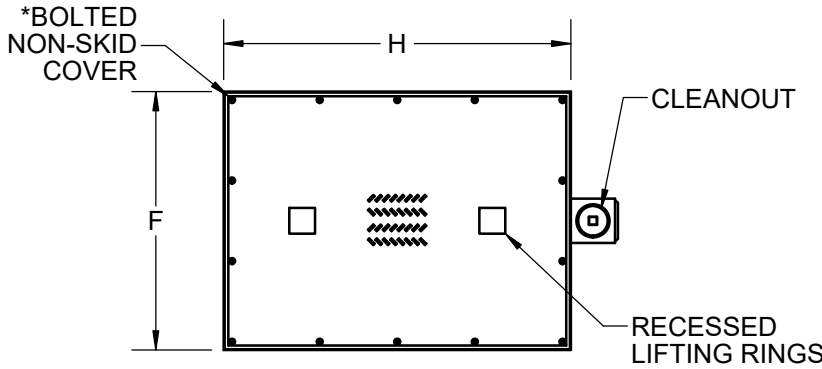

□ DIMENSIONS BASED ON STANDARD 6" EXTENSION

X	-EXT	EXTENSION, 6" STANDARD (SPECIFY EXT. HEIGHT)
Δ	-EST	EXTRA STORAGE TANK
	-60	ANCHOR FLANGE (4" DOWN FROM TOP)
	-61	FLANGE AND CLAMP DEVICE (4" DOWN FROM TOP)
	-HD	HEAVY-DUTY COVER (MUST SPECIFY WITH SEPARATOR ORDER)

SPECIFY:
D = _____
G = _____

Δ SEPARATE SUBMITTAL FOR THIS OPTION AVAILABLE

*THESE SIZES FURNISHED WITH ONE-PIECE COVER

	TYPE	FLOW RATE	PIPE SIZE	C	□D	E	F	□G	H	M	P	S
	*60611A	75	3	21	12	46-1/4	31	33	41	20-3/4	10-1/4	13-1/2
	*60612A	100	4	23	14	54	35	37	47	24	12-1/2	15-1/4
	*60613A	150	4	27	14	60	39	41	53	27	14-1/2	19-1/4
	60614A	200	5	31-1/2	16	67	42	47-1/2	58	29-5/8	16	26-1/4
	60615A	250	5	35-1/2	16	72	46	51-1/2	63	32-3/4	17-1/2	29-3/4
	60616A	350	6	39-1/2	18	80	52	57-1/2	71	36-1/2	19-3/4	34-1/4
	60617A	500	6	43-1/2	18	91	59	61-1/2	82	43	23	38-1/4

PRODUCT IS NON-CANCELABLE AND NON-RETURNABLE

NAME: _____ SIGNATURE: _____ DATE: _____

DATE OF LAST CHANGE: 9/19/23 JTJ

DIMENSIONS ARE SUBJECT TO MANUFACTURERS TOLERANCES AND CHANGE WITHOUT NOTICE. WE CAN ASSUME NO RESPONSIBILITY FOR USE OF SUPERSEDED OR VOID DATA.

JOSAM
MICHIGAN CITY, INDIANA

NOTES

WARNING: Cancer and Reproductive Harm - www.P65Warnings.ca.gov