

SPECIFICATION:

JOSAM 12724 SERIES COATED CAST IRON DOUBLE VERTICAL 4" NO-HUB ON STACK FITTING WITH 2" NO-HUB OFFSET VENT, ADJUSTABLE CARRIER BODY, INVERTIBLE FOR SIPHON JET OR BLOWOUT CLOSETS, WITH ABS EXTENSION WITH INTEGRAL TEST CAP, PYLON FEET, ANCHOR FOOT, PLATED HARDWARE AND NEOPRENE FIXTURE GASKET

**CLOSET CARRIER
VERTICAL BACK-TO-BACK**

SERIES

12724

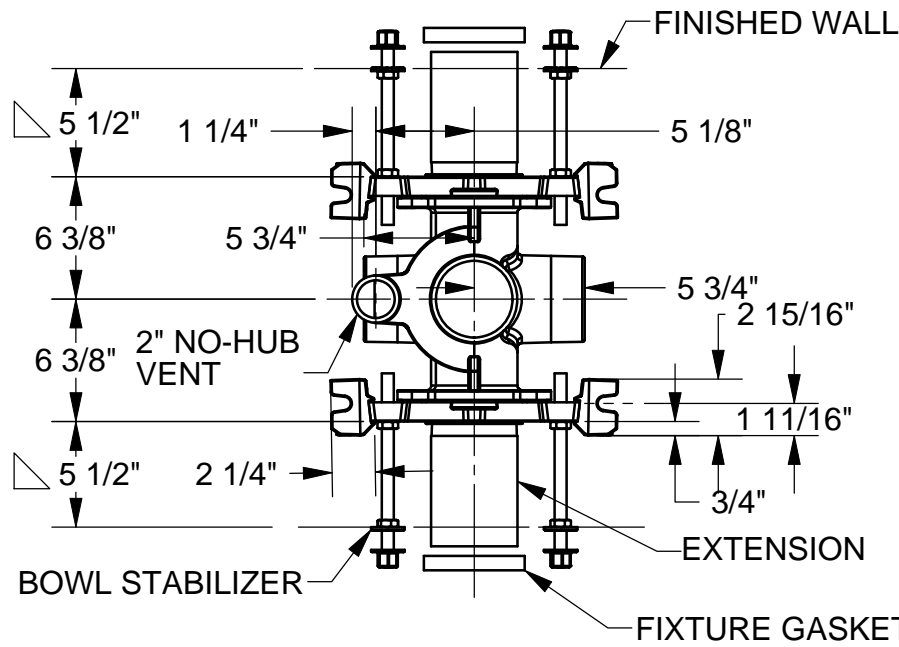

△ FOR DIMENSION SHORTER THAN 5-1/2" (1" MIN) CUT EXTENSION. FOR LONGER EXTENSION (10-1/2" MAX) SPECIFY (-10)

☒ RECOMMEND FEET BE SECURED TO FLOOR WITH 1/2" BOLTS AND ANCHORS (BY OTHERS).

⊗ FOR SIPHON JET ROUGHING OVER 6" OR BLOWOUT ROUGHING OVER 12-1/2" SPECIFY ON ORDER.

SIPHON JET DIMS SHOWN. FOR BLOWOUT DIMS, USE:

▱ MIN 11 & MAX 16-1/2"

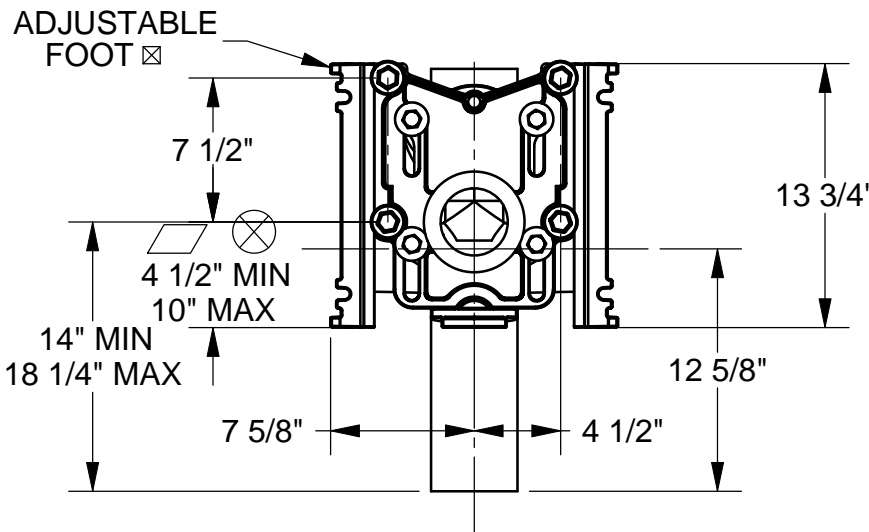

-XSD	EXTRA SPECIAL-DUTY 1,000 LB CARRIER
-PF	PYLON FOOT, STD.
-OR	O-RING CARRIER
-SD	SPECIAL-DUTY 500 LB. CARRIER
-HS	HUB & SPIGOT
-LH4	LEFT-HAND 4" NO-HUB BRANCH
-HLH4	LEFT-HAND 4" HUB BRANCH
-RH4	RIGHT-HAND 4" NO-HUB BRANCH
-HRH4	RIGHT-HAND 4" HUB BRANCH
-D4	DOUBLE 4" NO-HUB BRANCHES
-HD4	DOUBLE 4" HUB BRANCHES
-VP	VANDAL-PROOF TRIM

-1	POSITIONING FRAME
-6	SUPPLY PIPE SUPPORT (SPECIFY TYPE OF PIPE)
-10	ABS EXTENSION THROUGH 10-1/2" WALL
-24	FLOOR MOUNTED BACK OUTLET CHINA BOWL
-30	CAST IRON ADJ. EXTENSION W/ CONNECTOR
-30-2	CAST IRON ADJ. EXTENSION W/ CONNECTOR & TEST CAP
-32	CARRIER FOR WIDE CHASE INSTALLATIONS
-35	CARRIER FOR WHEELCHAIR HIGH ROUGH
-49	NO-HUB AUXILIARY INLET, UNDER VENT
-50	NO-HUB AUXILIARY INLET, OPPOSITE VENT
-53	THREADED AUXILIARY INLET, UNDER VENT
-54	THREADED AUXILIARY INLET, OPPOSITE VENT

DATE OF LAST CHANGE: 12/02/2010

DIMENSIONS ARE SUBJECT TO MANUFACTURERS TOLERANCES AND CHANGE WITHOUT NOTICE. WE CAN ASSUME NO RESPONSIBILITY FOR USE OF SUPERSEDED OR VOID DATA.

JOSAM COMPANY
MICHIGAN CITY, INDIANA

NOTES