

30000-PFB

Floor Drain Adjustable Base

Specification

30000-PFB Series floor drain assembly with galvanized steel drain base and two-piece coated cast iron body. Features include double drainage flange, Wejloc® flashing collar with weepholes, threaded connection for adjustable strainer, no-hub bottom outlet, and threaded rod with hardware for height adjustment.

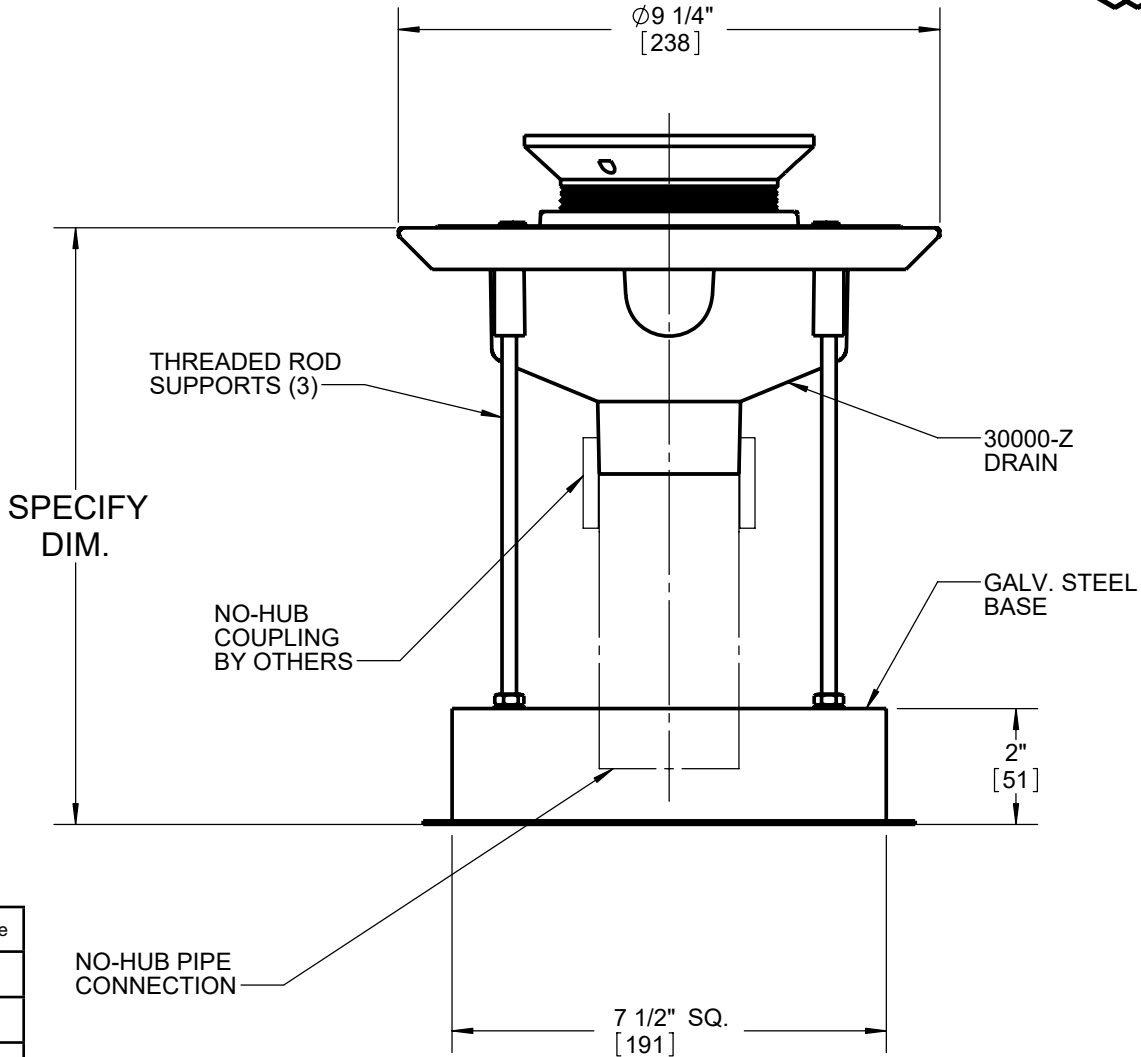
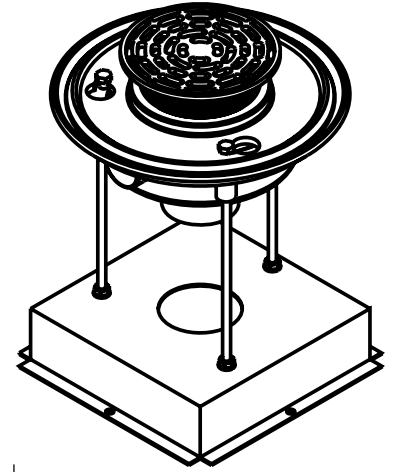

| | Pipe size |
|--|-----------|
| | 2" |
| | 3" |
| | 4" |

Josam product specifications in U.S. customary units are approximate and provided for reference only. For precise measurements, please contact Josam Technical Support. Josam reserves the right to change or modify product design, construction, specifications, or materials without prior notice and without incurring any obligation to make such changes and modifications on Josam products previously or subsequently sold.

Notes:



A WATTS Brand