

60210A-SAP

Grease Interceptor

Manual High-Volume Type

Specification

Josam 60210A-SAP series acid resistant epoxy coated fabricated steel grease interceptor, high volume, threaded connections, internal air-relief, visible double wall trap, removable diffuser baffle, gasketed non-skid cover, flow control fitting and factory installed Josam SAP sensing and alarm probe.

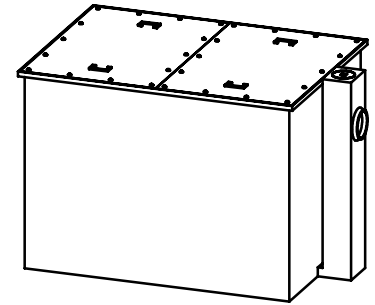

*This size furnished with one-piece cover.

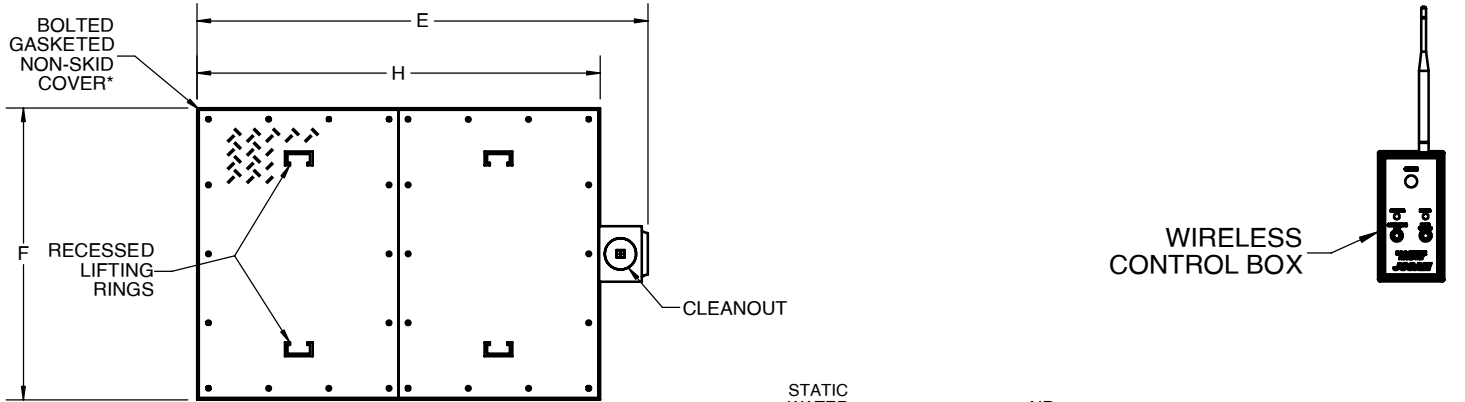

X	-SAP	Sensing and alarm probe
	-EXT	Extension, 6" standard (specify extension height)
	-60	Anchor flange
	-61	Flange and clamp device
	-ISI	Integrated solids interceptor
	-HD	Heavy-duty cover

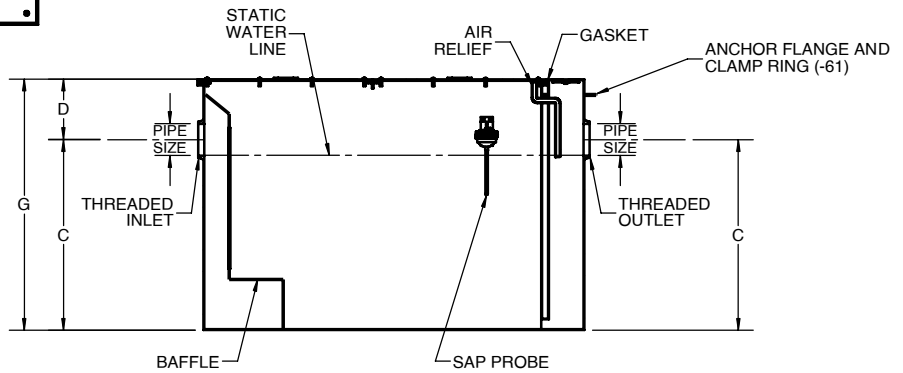

	Type	Flow rate	Cap LBS	Pipe size	C	D	E	F	G	H
*	60213A	150	300	4	27	8	60	39	35	53
	60214A	200	400	5	31-1/2	10	67	42	41-1/2	58
	60215A	250	500	5	35-1/2	10	72	46	45-1/2	63
	60216A	350	700	6	39-1/2	12	80	52	51-1/2	71
	60217A	500	1000	6	43-1/2	12	91	59	55-1/2	82

Josam product specifications in U.S. customary units are approximate and provided for reference only. For precise measurements, please contact Josam Technical Support. Josam reserves the right to change or modify product design, construction, specifications, or materials without prior notice and without incurring any obligation to make such changes and modifications on Josam products previously or subsequently sold.

Notes:



A WATTS Brand