

SPECIFICATION:

JOSAM 60610A-EST STEEL OIL INTERCEPTOR, FLUSH-WITH-FLOOR TYPE WITH OIL STORAGE TANK, THREADED CONNECTIONS, FLAT BOTTOM, VISIBLE DOUBLE WALL TRAP, SEDIMENT BUCKET, GASKETED COVER, ACID RESISTANT COATING (INSIDE AND OUT), CHECK VALVE AND FLOW CONTROL FITTING.

**OIL INTERCEPTOR
WITH INTERNAL OIL
STORAGE TANK**

SERIES **60610A-EST**

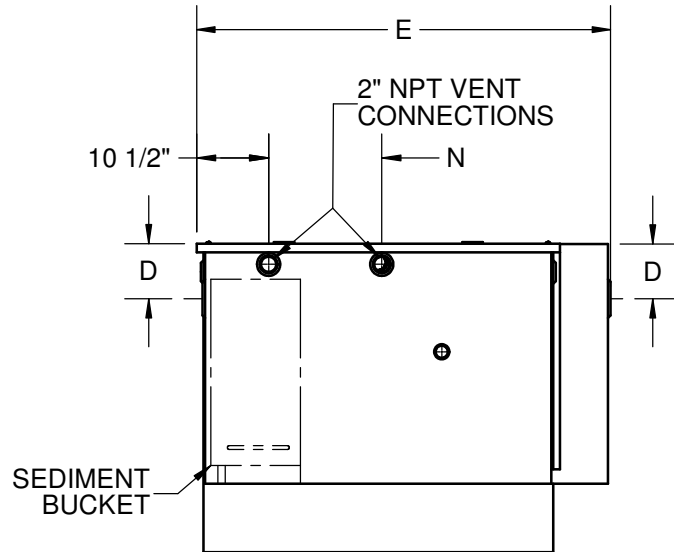
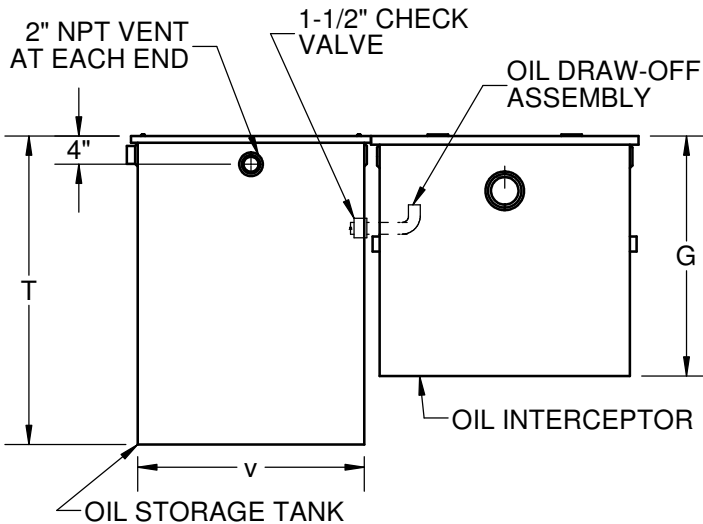
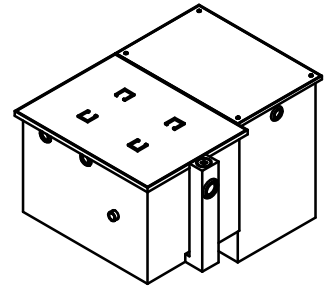
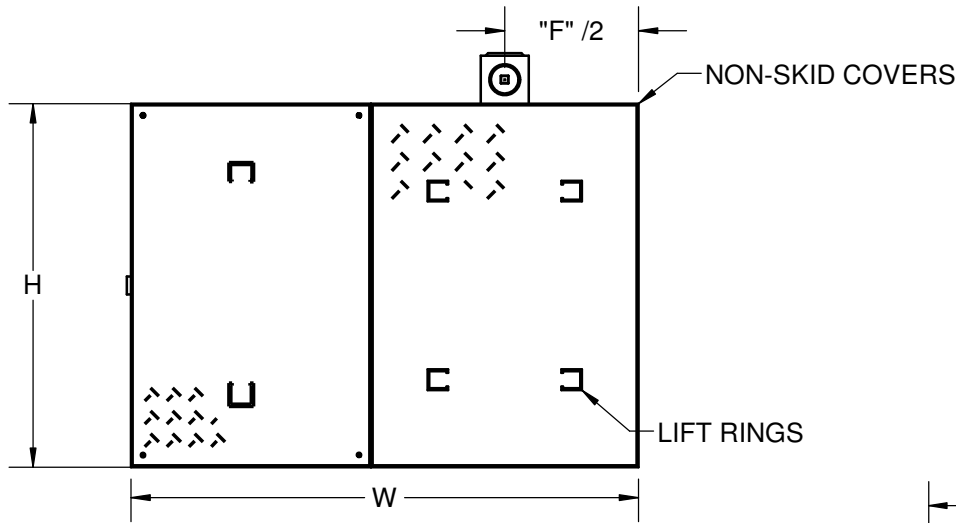

-19	RECLAIM TANK ALARM
-EXT	EXTENSION (SPECIFY "D" DIMENSION) MINIMUM "D" DIMENSION = 8"

TYPE	FLOW RATE	TANK SIZE (GAL.)	PIPE SIZE	D	E	F	G	H	N	T	V	W	WEIGHT (LBS.)	** FLOW CONTROL
60611A-EST	75	100	3	8	46	31	29	41	12	37	24	59	1200	60714
60612A-EST	100	250	4	8	54	35	31	47	14	48	35	70	1500	60714
60613A-EST	150	250	4	10	60	39	37	53	16	45	35	74	2000	60714
*60614A-EST	200	250	5	15	67	42	49	54	18	48	35	77	2400	60715
*60615A-EST	250	500	5	15	72	46	51	63	20	60	45	91	3000	60715
*60616A-EST	350	500	6	15	80	52	55	71	23	56	45	97	3800	60716
*60617A-EST	500	500	6	26	91	59	70	83	27	66	45	104	5200	60716

*FURNISHED WITH 2 PIECE COVER

**FLOW CONTROL INCLUDED AS STANDARD (NOT SHOWN)

DATE OF LAST CHANGE: 9/5/14

DIMENSIONS ARE SUBJECT TO MANUFACTURERS TOLERANCES AND CHANGE WITHOUT NOTICE. WE CAN ASSUME NO RESPONSIBILITY FOR USE OF SUPERSEDED OR VOID DATA.

JOSAM COMPANY
MICHIGAN CITY, INDIANA

NOTES