

SPECIFICATION:

JOSAM FD-450J-S SERIES PVC DRAIN BODY WITH
 THREADED ADJUSTABLE SUPER-FLO SQUARE NIKALOY
 STRAINERS. COMBINATION 3" X 4" SOLVENT WELD
 BOTTOM OUTLET FITS OVER 3" OR INSIDE 4" SCHEDULE
 40 PVC PIPE.

FLOOR DRAIN

PVC

SERIES

FD-450J-S

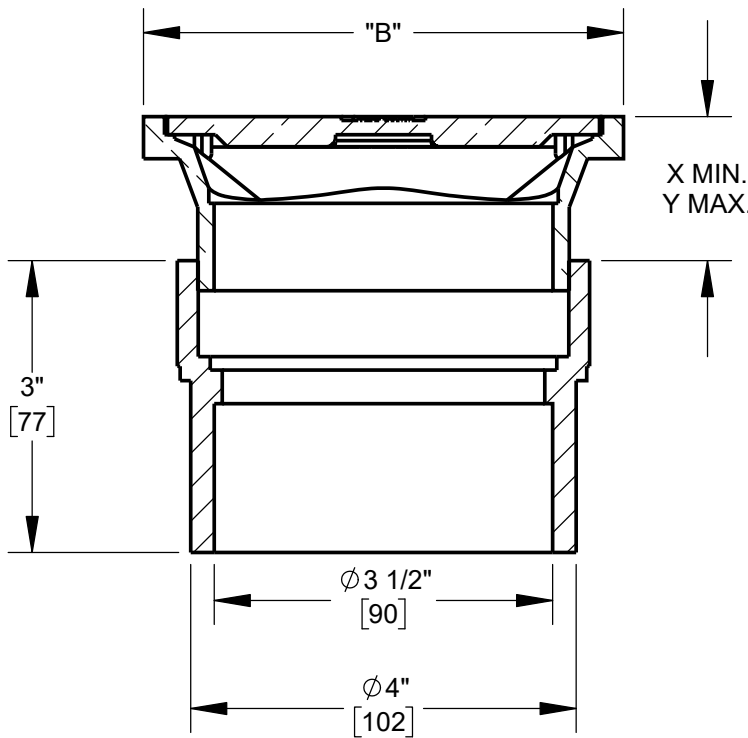
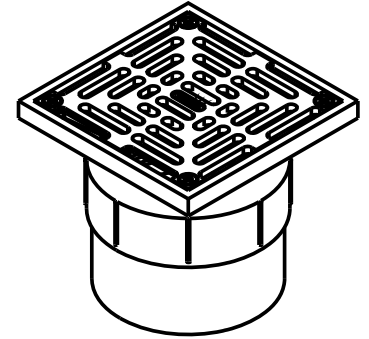
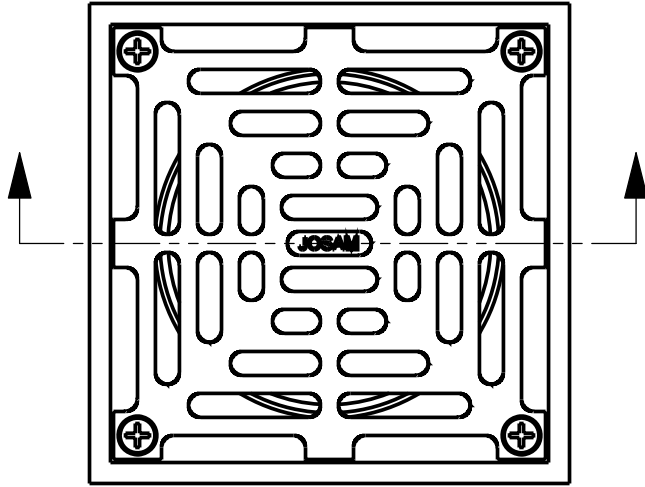

OPTIONS:

-2	SATIN FINISH BRONZE TOP
-VP	SECURED GRATE, VP SCREWS

STRAINER	DIA. B	X	Y	FREE AREA
-5S	5	1	2	9.1
-6S	6	1-1/4	2-1/4	13.8
-8S	8	1-1/2	2-3/4	24.5

DATE OF LAST CHANGE: 06/27/18

DIMENSIONS ARE SUBJECT TO MANUFACTURERS
 TOLERANCES AND CHANGE WITHOUT NOTICE.
 WE CAN ASSUME NO RESPONSIBILITY FOR
 USE OF SUPERSEDED OR VOID DATA.



MICHIGAN CITY, INDIANA

NOTES