

SPECIFICATION:

JOSAM 12000-CR SERIES COATED CAST IRON ADJUSTABLE CARRIER BODY, INVERTIBLE FOR SIPHON JET OR BLOWOUT CLOSETS, INCLUDES ANCHOR FOOT, JIFFY SEAL GASKET, COMPRESSION NUT AND O-RING SEAL.

**COMPRESSION RING
CARRIER ASSEMBLY**

SERIES **12000-CR**

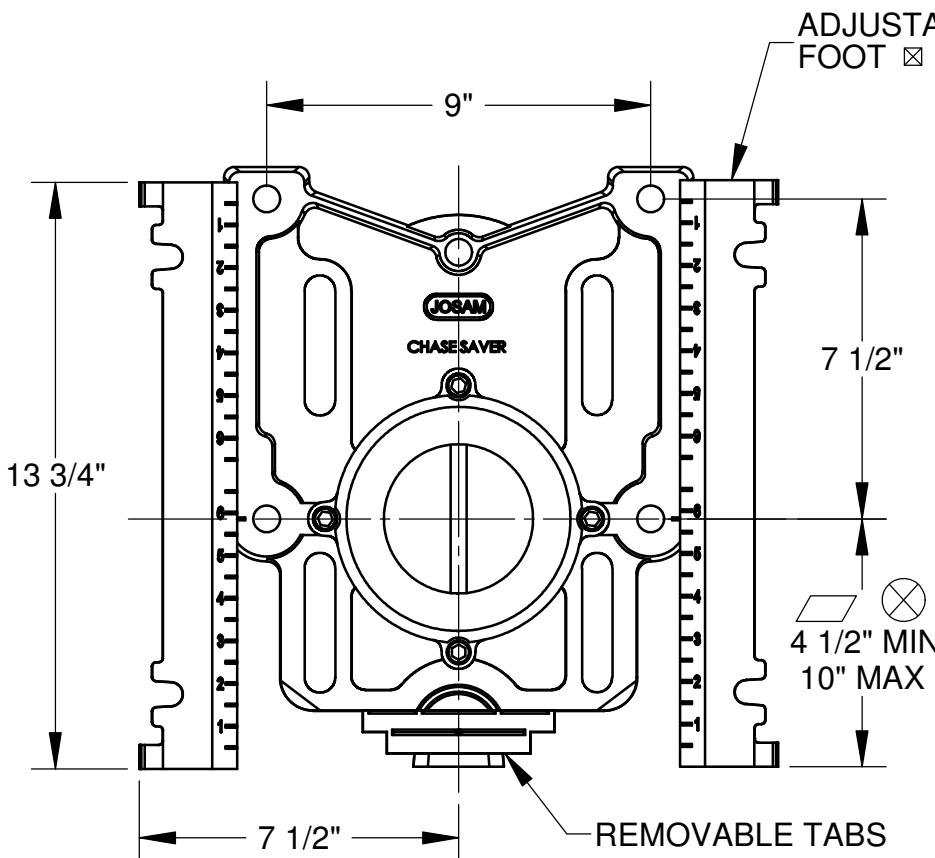
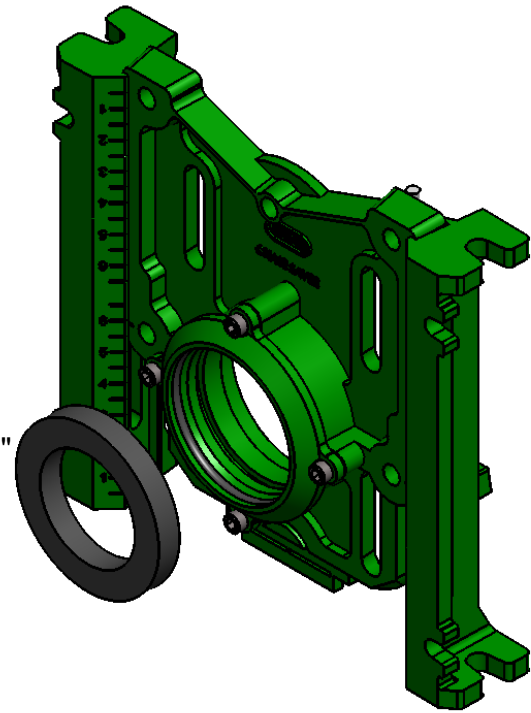
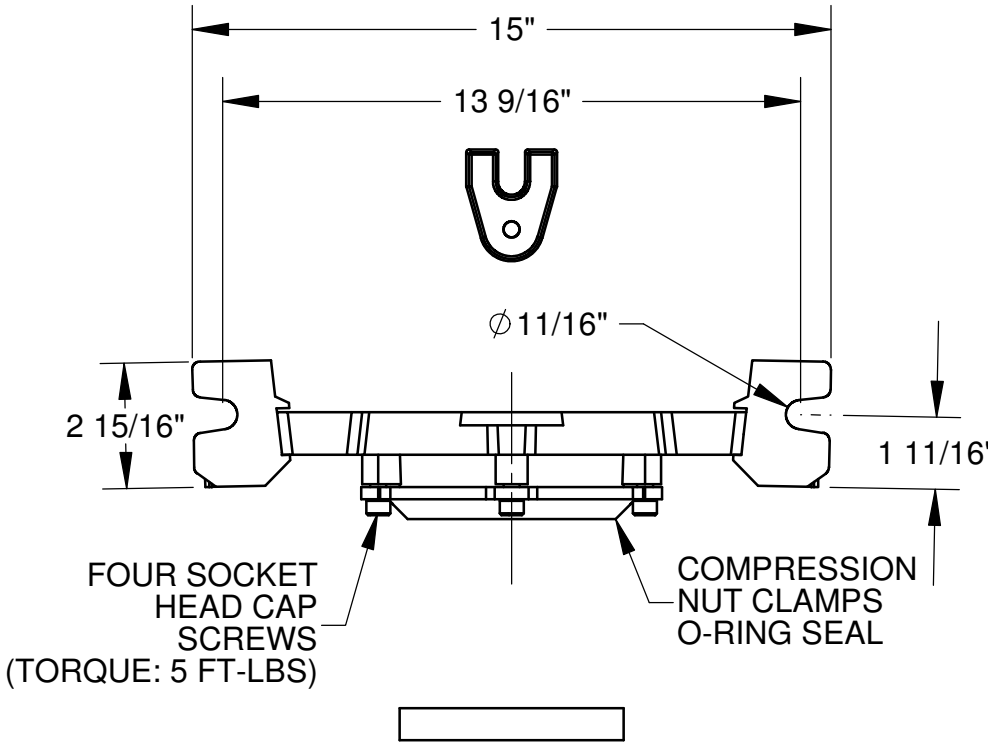

NOTE:
SEE SPECIFICATION
FROM CARRIER FITTING
FOR SYSTEM OPTIONS

- ⊠ RECOMMEND FEET BE SECURED TO FLOOR WITH 1/2" BOLTS AND ANCHORS (BY OTHERS).
- ⊗ FOR SIPHON JET ROUGHING OVER 6" OR BLOWOUT ROUGHING OVER 12-1/2" SPECIFY ON ORDER.

SIPHON JET DIMS SHOWN.
FOR BLOWOUT DIMS, USE:

▱ MIN 11" & MAX 16 1/2"

WARNING: Cancer and Reproductive Harm - www.p65warnings.ca.gov

DATE OF LAST CHANGE: 2/11/2014

DIMENSIONS ARE SUBJECT TO MANUFACTURERS TOLERANCES AND CHANGE WITHOUT NOTICE. WE CAN ASSUME NO RESPONSIBILITY FOR USE OF SUPERSEDED OR VOID DATA.

JOSAM COMPANY
MICHIGAN CITY, INDIANA

NOTES