

# CLOSET CARRIERS

## 12000-PF Series CHASE-SAVER® II Features

JOSAM 12000-PF Series CHASE-SAVER® II Closet Carrier meets the most rigid requirements for securing and supporting water closets. Some of the many specification and installation features are shown below. CHASE-SAVER® II can be used to mount either siphon jet or blow-out closets by inverting the carrier body. This carrier was specifically designed for pre-fabricated plumbing systems and exceeds the requirements of American National Standard ANSI A112.6.1M-1997. Pre-assembled carrier and pylon feet are packed with all the hardware. The extension and fitting are shipped separately for convenient handling at the fabrication or job site.

### FITTING GASKET

Neoprene gasket with raised "O" ring beads on both sides provides a positive watertight seal between fitting and carrier.

### PYLON FEET

Heavy-duty cast iron, compact, invertible (same foot both sides – no rights and lefts) outboard side mount for easy access to all assembly hardware, with "Wrap around" carrier retaining channel (1) which "locks" foot to carrier with only one bolt (2). Each foot requires only one floor anchor bolt and has additional "convenience" slots (3) for securing pre-fab transport frames, and pipe supports, incorporates handy elevation scale (4) divided in 1/2" increments on front to permit roughing-in at a glance, extends only 3/4" in front of carrier with flat vertical face and 13-3/4" height accommodates either standard or high rough mounting.

### ANCHOR FOOT

Cast iron, rotatable, secured to back of fitting by means of fully threaded rod for complete adjustment, provides the final link in the 3 point support system for ultimate stability of the installation.

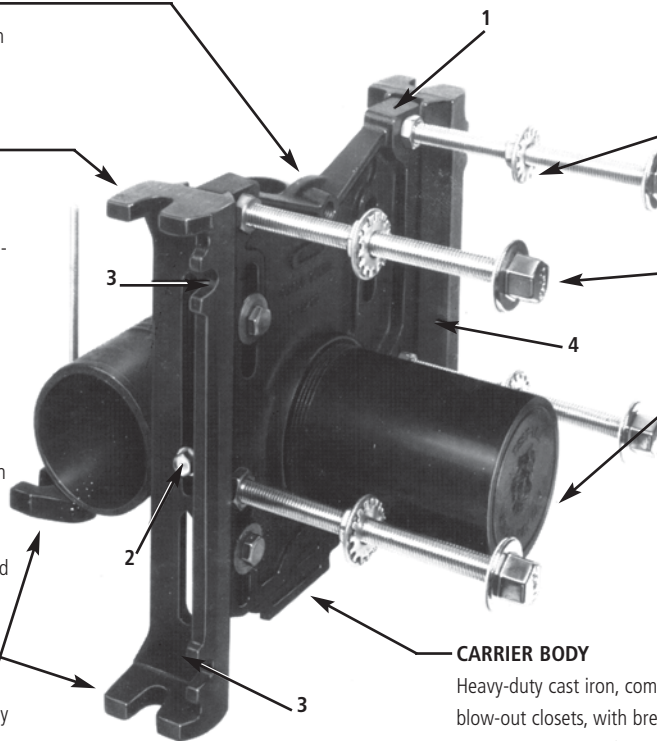

### FIXTURE GASKET

JIFFEE-SEAL Neoprene Gasket fits all closet gasket recesses.

### BOWL STABILIZER BACK UP WASHERS

Provide gripping power necessary to prevent water closet from settling out of installed location over a long period of time.

### HARDWARE

Zincbrite plating protects all hardware and cap nuts are finished in chrome.

### ADJUSTABLE EXTENSION

High strength ABS plastic with built-in test cap, assembled to carrier body with positive taper threads, easily cut to desired length. Furnished 7" long standard for 1" minimum to 5-1/2" maximum dimension, and 12" long (specify -10 Option) for 10-1/2" maximum dimension.

### CARRIER BODY

Heavy-duty cast iron, compact, invertible for positive support of siphon jet or blow-out closets, with break-off tabs for rough-in less than standard 5-1/2", at the base (in siphon jet position), accommodates complete range of rough-in heights in two models, one (standard) for 4-1/2" through 6" and the other for higher rough, bolts directly to fitting. Bolt securing standard, stud securing is optional.

**SPECIFICATION:** JOSAM 12000-PF Series coated cast iron CHASE-SAVER® II Closet Carrier with adjustable connection, adjustable pylon feet, ABS extension with integral test cap, chrome plated trim, coated accessories and JIFFEE-SEAL Neoprene fixture gasket, for use with blowout or siphon jet water closets.

