



CEGOLD-2000
Electronic Grease Level Detector
For Use With Concrete Interceptor Probes
Installation and Operating Procedures

 **WARNING:** Cancer and Reproductive Harm - www.p65warnings.ca.gov

Josam Company
2501 South Front Street
Philadelphia, PA 19148
215-339-5370
www.JOSAM.com

REV F 01/17/06

Table of Contents

1.0	General Description	3
2.0	CEGOLD-2000 INSTALLATION	5
3.0	CEGOLD-2000 Controls and Indicators.....	10
4.0	CEGOLD-2000 CALIBRATION	12
5.0	CEGOLD-2000 OPERATION.....	14
6.0	CEGOLD-2000 MAINTENANCE.....	16

Figures

Figure 1-1	Illustration of the ELECTRONIC GREASE LEVEL DETECTION SYSTEM	4
Figure 2-1	Illustration of an installed TANK PROBE ASSEMBLY	8
Figure 2-2	Illustration of TANK PROBE ASSEMBLY WIRING.....	9
Figure 3-1	Illustration of the CONTROLLER UNIT FACE.....	11

Appendices

Appendix I	Not used	17
Appendix II	Optional External Alarm Unit	18
Appendix III	Optional External Modem.....	19

1.0 General Description

The CEGOLD-2000 Electronic Grease Level Detector product consists of the following components:

- A wall mounted Control Unit that contains the level measurement micro-controller electronics, control switches and indicators.
- A Tank Probe assembly consists of a Concrete Interceptor Tank Probe, mounting shaft, mounting bracket and mounting hardware. Multiple size extension shaft lengths are available to fit most existing concrete interceptor configurations.
- A U.L. approved wall mount low voltage power module.
- A cable and junction box for connection to the wall mounted Control Unit.
- A cable and junction box for connection to Tank Probe.

Note: A four-conductor cable (minimum 22 ga.) is required for connection between the junction box (This cable is not supplied by Josam).

The Control Unit GLS housing, connectors, control switches and indicators are water resistant for splash or spray conditions. The Tank Probe is a sealed against water penetration.

The CEGOLD-2000 Electronic Grease Level Detector product provides the following functions and features:

- Provides a continuous grease level measurement system that can be calibrated to concrete interceptor configurations.
- Provides an integral level alarm to alert the user of the need for interceptor cleaning.
- Provides a switch closure for a remote level alarm option.
- Provides an easy method of alarm level calibration.
- Provides an interface for an external Modem option that allows remote monitoring of the system by telephone.

Figure 1-1 provides an illustration of the CEGOLD-2000 System used with a Concrete Interceptor Probe assembly.

CEGOLD-2000 Electronic Grease Level Detector
For use with Concrete Interceptor Probes
Installation and Operating Procedures

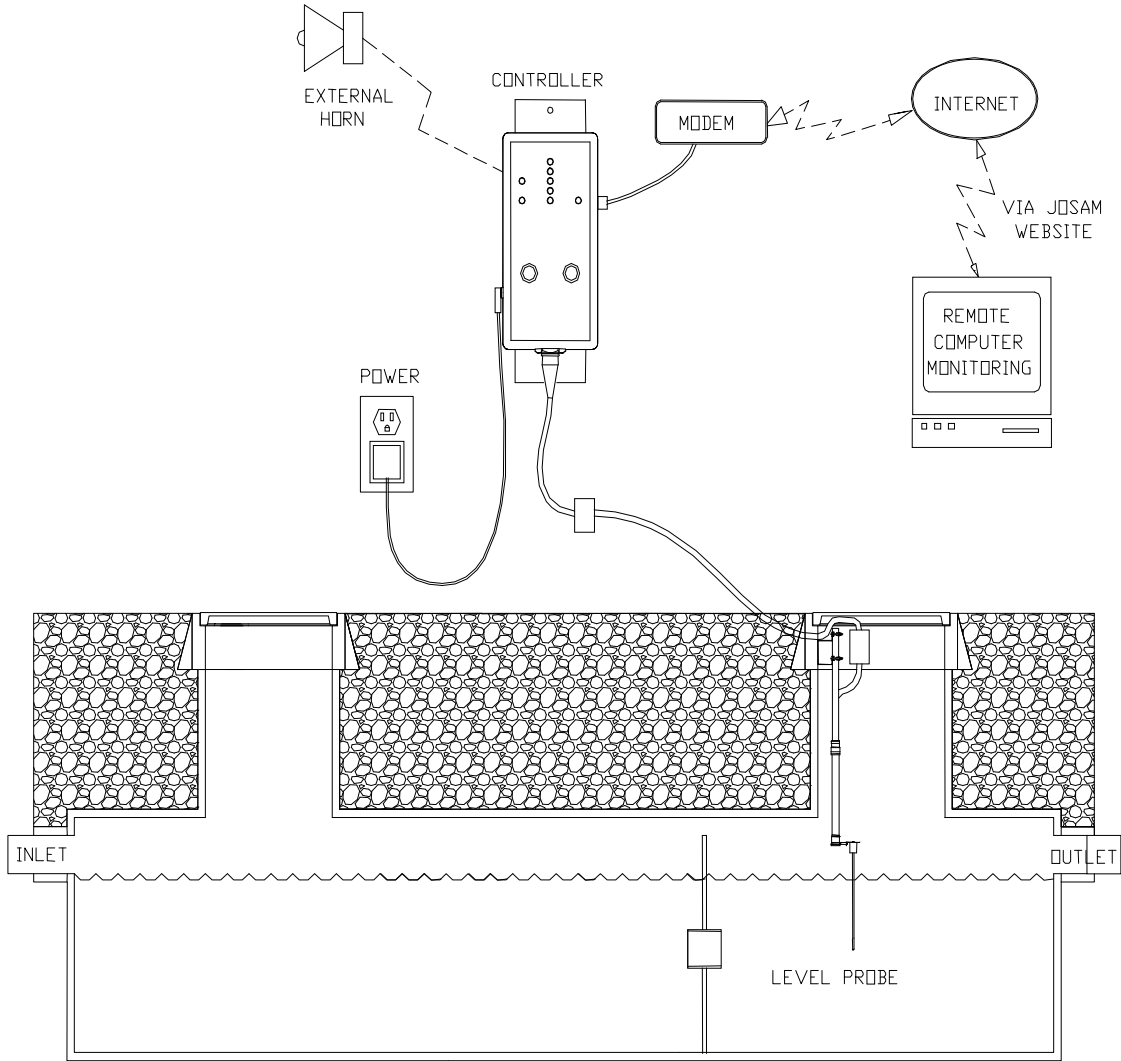

Figure 1-1

CEGOLD-2000 System

2.0 CEGOLD-2000 Installation

2.1 Important Installation Points

- Check that you have selected the proper extension shaft for the Concrete Interceptor Probe assembly to suit your particular concrete interceptor tank requirements. The extension shaft length should allow adjustment of the probe assembly such that the top calibration line on the probe matches the static water level in the Concrete Interceptor Tank when installed in the manhole.
- Prior to installing the Concrete Interceptor Probe assembly in the Interceptor Tank, the grease and solids must be cleaned out of the Concrete Interceptor. Refill the tank with water until the static water level is reached.
- Prior to installing the Concrete Interceptor Probe assembly in the Interceptor Tank, insure that there are no pipes, etc. in the manhole cover frame that will interfere with the installation.
- It is important to carefully follow the calibration procedure outlined below, in order to insure proper grease level detection.
- **The wall mount power module that powers the Control Unit must be directly plugged into an outlet. Do not use an extension cord. If electric service is required, a licensed and certified electrician must install it.**

2.2 Control Unit Installation

The Control Unit has integral mounting brackets for wall mounting.

Install the Control Unit as follows:

- 1) Find a wall location that is within 100 feet of the interceptor and within 5 feet of an 115VAC wall outlet.

Note: For longer distances increase the four-conductor cable wire to 18 ga.

- 2) Place the Control Unit on the wall and mark the two (2) mounting hole locations. Drill 3/16" holes to accept the mounting hardware.
- 3) Use the mounting hardware provided to fasten the Control Unit to the wall.
- 4) Mount the Controller Junction provided near the Control Unit location so that the cable provided with the Controller Junction Box can be plugged into the bottom of the Control Unit (as indicated in Figure 1-1).
- 5) Remove the Controller junction box cover. Run the cable that comes from the Probe Junction Box in the manhole into the unused end of the Controller junction box and wire nut the cable to the existing 4 conductor cable already installed in the Controller junction box. (See Figure 2-2 for wire connections). Reattach the Controller Junction Box cover.
- 6) Attach the cable connector from the Controller Junction Box to the Control Unit.
- 7) Plug the power module provided into the wall and plug the power module cord into the Control Unit. Note: The LED indicators should flash ON then OFF when the unit is properly powered.

See Appendix II for optional remote level alarm installation procedure.

See Appendix III for optional Modem installation procedure.

2.3 Concrete Interceptor Probe Assembly Installation

The Concrete Interceptor Tank Probe Assembly consists of the following:

- Probe pipe mounting brackets
- Probe mounting pipe
- Probe mounting bracket
- Tank Probe
- Junction Box

Figure 2-1 illustrates the Concrete Interceptor Tank Probe Assembly.

Install the Concrete Interceptor Tank Probe Assembly as follows:

- 1) Remove the manhole from the Concrete Interceptor Tank.
- 2) The cable from the Control unit to the manhole must be installed. Typically this cable is run thru an underground conduit and enters through a hole cut into the side of the manhole cover frame. Leave ~ 3 ft. of loose cable inside the manhole.
- 3) Attached the Probe Junction Box provided to the sidewall of the manhole cover frame (as indicated in Figure 1-1). Remove the junction box cover. Run the cable into the unused end of the junction box and wire nut the cable to the existing 4 conductor cable already installed in the junction box. (See Figure 2-2 for wire connections). Reattach the Probe Junction Box cover.
- 4) Select a location for the Concrete Interceptor Probe assembly in the Interceptor Tank, insure that there are no pipes, etc. in the manhole cover frame that will interfere with the installation.
- 5) At the selected location install the probe pipe mounting bracket anchors provided to the manhole cover frame a minimum of 6" apart.(as indicated in Figure 1-1).
- 6) Measure the distance from the upper probe pipe mounting bracket anchor to the invert water line. Cut the mounting pipe to the measured length.
- 7) Clamp the probe mounting bracket ~1" from the end of the pipe as shown in Figure 2-1. Attach the Measurement Probe to the probe mounting bracket as shown in Figure 2-1.
- 8) Slide the Probe shaft mounting brackets over the pipe. Tighten the pipe in place so that ~ 3.75" of the probe mounting pipe remains above the upper probe pipe mounting bracket anchor.

- 9) Check that the top of the probe mounting bracket is 4.75" from the invert water line.
- 10) Connect the cable connector attached to the Junction Box to the Measurement Probe connector.

Note: Be careful not to bend, scrape or otherwise damage the probe shaft when mounting the Tank Probe assembly.

This completes the installation of the CEGOLD-2000 Electronic Grease Level Detector system.

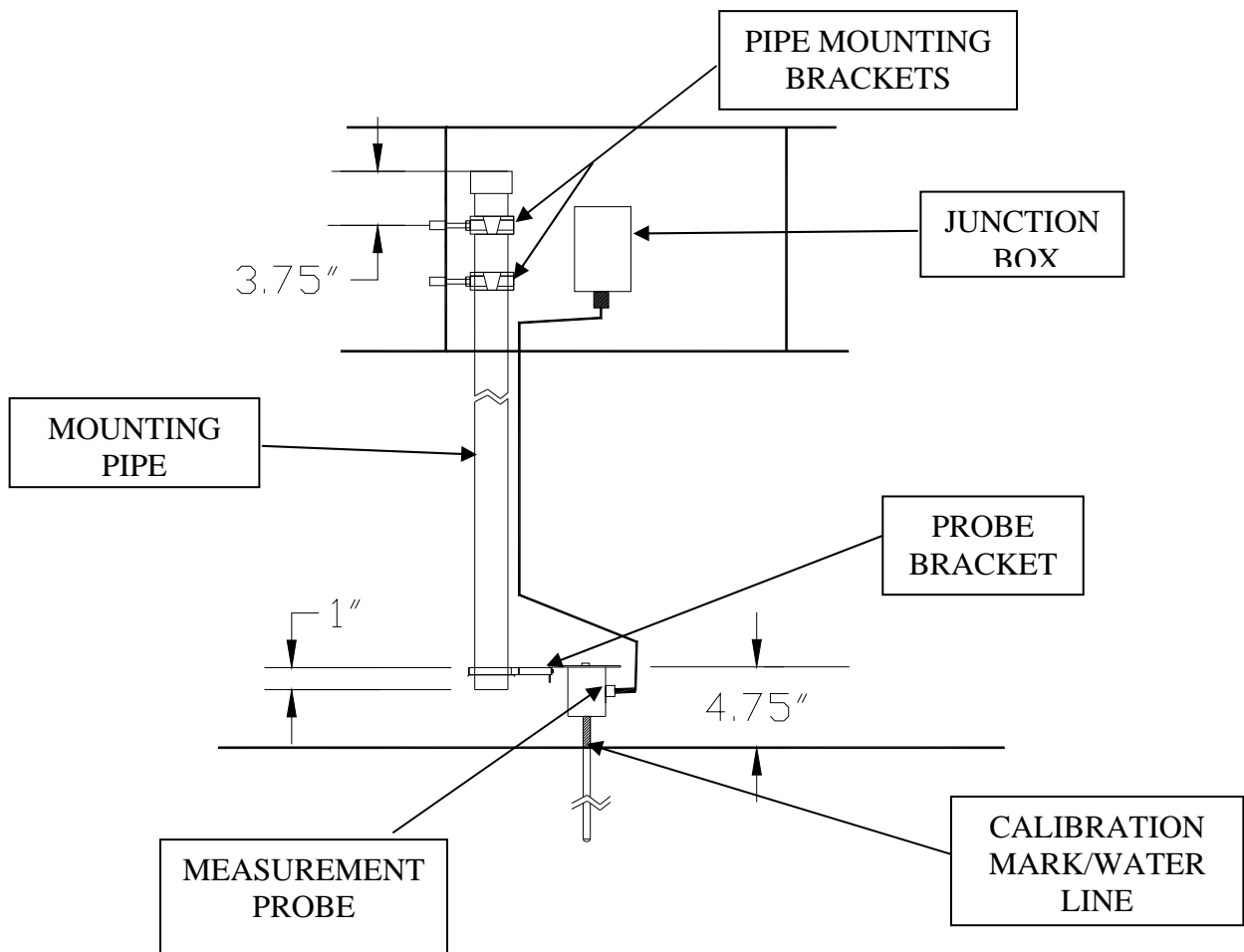

Figure 2-1
Concrete Interceptor Probe Assembly

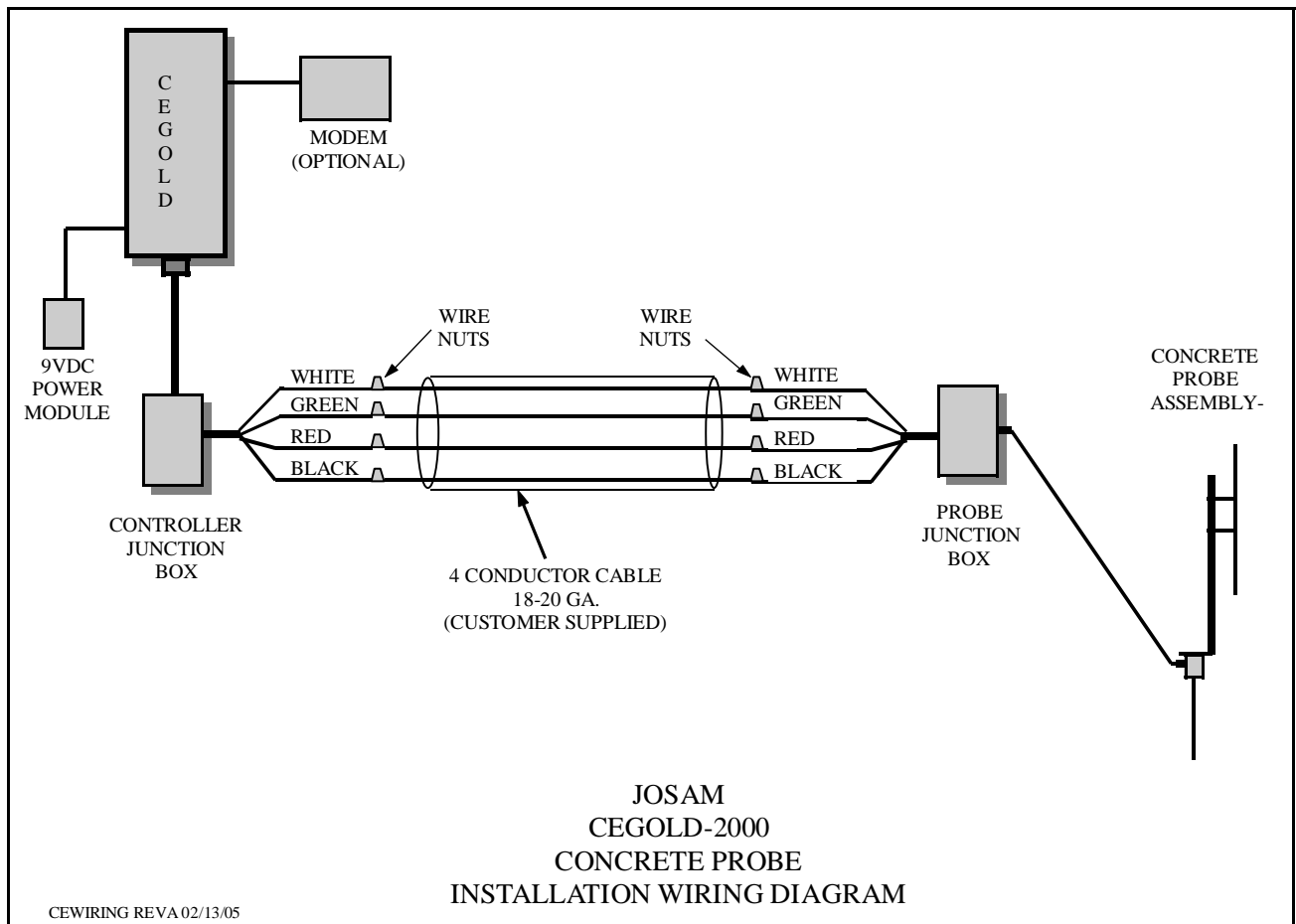

Figure 2-2

3.0 CEGOLD-2000 Controls and Indicators

3.1 Control Unit

The face of Control Unit has two (2) momentary push button controls:

Cal Set Button -This button is pressed to initiate a calibration procedure.

Horn Reset Button -This button is pressed to turn off the level alarm buzzer.

The face of the Control Unit has the following LED indicators:

Run LED When ON this LED indicates that the CEGOLD-2000 Electronic Grease Level Detector system is operating properly in the grease level detection mode.

Cal LED When ON this LED indicates that the CEGOLD-2000 Electronic Grease Level Detector system is in the grease level calibration mode.

Level LEDs A set of 5 vertical LED indicators displays the current level of grease being detected in the interceptor tank. Each LED indicator represents approximately one fifth (1/5) of the maximum grease level volume.

The bottom two (2) *Green* LEDs indicate the grease volume is below the level required for grease interceptor tank cleaning. Note: The two (2) *Green* LED indicators are also used during the system calibration.

The two (2) *Yellow* LEDs indicate the grease volume is approaching the level required for cleaning the grease interceptor tank.

The *Red* LED indicates the grease volume has reached the level requiring the grease interceptor tank to be cleaned.

Clean LED When ON this LED indicates that the grease interceptor tank requires cleaning.

Figure 3-1 illustrates the face of the Control Unit.

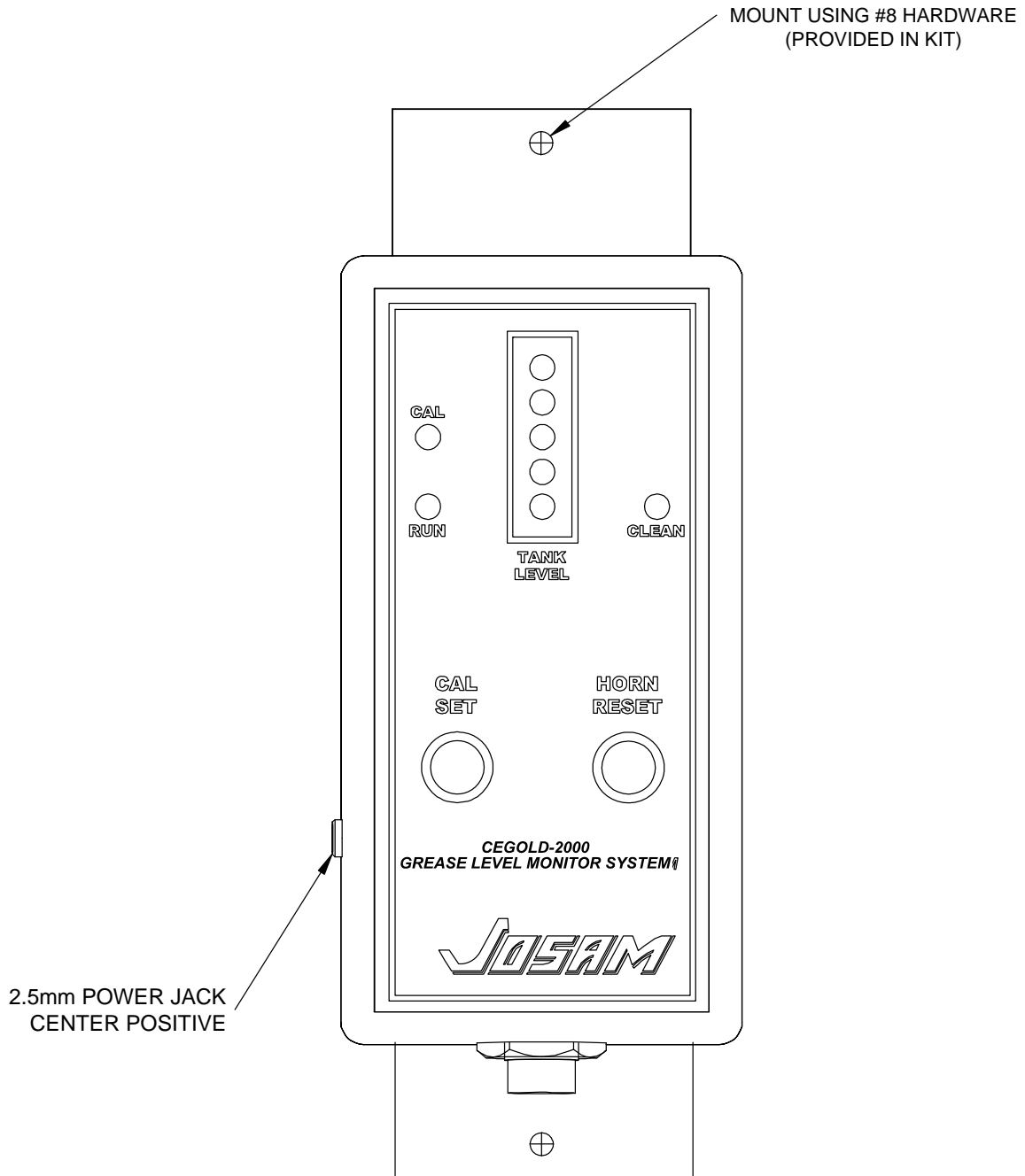

Control Unit Face

Figure 3-1

4.0 CEGOLD-2000 Calibration

The CEGOLD-2000 Electronic Grease Level Detector system when used with a Concrete Interceptor Probe assembly is pre-calibrated at the factory. The grease level at which the alarm (Horn) sounds indicating that the grease interceptor is due for cleaning is also preset at the factory. Typically the alarm level is approximately 1/3 of the distance between the bottom of the outlet pipe on the interceptor tank and the bottom of the tank.

However, there may be factors at the installation that may create a level measurement offset when installed in the field. For example, The static water level may not line up with the top calibration mark on the Concrete Interceptor probe.

After installation, it is recommended that the following calibration procedure be performed to minimize calibration errors in the field.

4.1 Calibration Procedure

Perform the following steps to calibrate a newly installed CEGOLD-2000 Electronic Grease Level Detector system:

- 1) Start with the Control Unit unpowered (power module removed from the wall socket).
- 2) Ensure that the interceptor tank has been cleaned prior to Concrete Interceptor Probe assembly installation and is filled with water to the static water level..
- 3) Power up the Control Unit (plug power module into the wall socket) The LED indicators should flash ON then OFF (the horn will also beep) to indicate Power has been applied.
- 4) The Control Unit LED indicators should be in the following states:
 - **Run** LED is ON
 - **Cal** LED is OFF
 - The other **Level Indicating** LEDS are typically OFF

Note: If the **RED** Level LED is flashing Contact JOSAM for technical support .

- 5) Press the **Cal Set** Button on the Control Unit. The CAL LED will start flashing indicating the Control Unit is in the calibration mode.

Note: Calibration mode can be cancelled at any time by pressing the Alarm Reset Button.

- 6) Wait for multiple beeps to occur and one of the Level LED indicators to turn ON. This indicates the Control Unit has completed the calibration measurement.
- 7) If the center Level LED is ON the unit is properly calibrated. Press the ***Alarm Reset*** Button and hold until multiple beeps occur. This concludes the calibration procedure and returns the Control Unit to normal operation. If not continue with the next step.
- 8) If either of the upper two Level LEDs are ON then press and release the ***Alarm Reset*** Button until the center Level LED is ON. The unit is now properly calibrated. Press the ***Cal Set*** Button and hold until multiple beeps occur. This concludes the calibration procedure and returns the Control Unit to normal operation. If not continue with the next step.
- 9)) If either of the lower two Level LEDs are ON then press and release the ***Cal Set*** Button until the center Level LED is ON. The unit is now properly calibrated. Press the ***Cal Set*** Button and hold until multiple beeps occur. This concludes the calibration procedure and returns the Control Unit to normal operation. If not continue with the next step.

Note: Contact JOSAM for technical support if system calibration is not successful the second time.

This completes the installation of the CEGOLD-2000 Electronic Grease Level Detector system.

5.0 CEGOLD-2000 Operation

Once the CEGOLD-2000 Electronic Grease Level Detector system is calibrated, operation is fully automatic and requires no operator interaction.

Normal Operation

The CEGOLD-2000 Electronic Grease Level Detector system operates as follows:

- The interceptor grease level is continuously monitored.
- The **Level Indicating LEDs** provide an indication of the current level.
 - The bottom two (2) **Green** LEDs indicate the grease volume is below the level required for grease interceptor tank cleaning.
 - The Two (2) **Yellow** LEDs indicate the grease volume is approaching the level required for cleaning the grease interceptor tank.
 - The **Red** LED indicates the grease volume has reached the level requiring the grease interceptor tank to be cleaned.
- The audible Alarm will sound once the **Red** LED indicates the grease volume has reached the level requiring the grease interceptor tank to be cleaned

Note: If installed, the optional Alarm will also sound at this time.

- Pressing the Horn Reset Button on the Control Unit can silence the Alarms.

Note: The audible alarm will again sound after several minutes if the grease volume is still at the level requiring the tank to be cleaned.

- Power should be removed from the Control Unit (unplug power module from the wall socket) when cleaning the grease interceptor tank.

Note: The CEGOLD-2000 Electronic Grease Level Detector system will maintain calibration when unpowered.

Error Indications

The Control Unit will indicate a system operating error as follows:

- The **Run** LED will be OFF.
- The **Red** Level LED will be flashing.
- The audible Alarm will sound intermittently (short beeps once every ten seconds).

System errors include:

- Loss of a proper signal from the Tank Probe Assembly
 - disconnected or broken cable to Tank Probe Assembly
 - electronic failure in the Tank Probe Assembly
- System Calibration improper
 - Tank Probe Assembly level signal outside the calibration limits

6.0 CEGOLD-2000 Maintenance

The CEGOLD-2000 Electronic Grease Level Detector system maintenance requirements are as follows:

- The Control Unit should be unpowered (power module removed from the wall socket) during maintenance operations.
- The Control Unit requires no periodic maintenance.

Note: The Control Unit is water resistant. Therefore the Control unit face may be cleaned with a damp cloth as required.

- The Concrete Interceptor Tank Probe Assembly requires that the tank probe be cleaned of grease or debris that may be stuck to the probe periodically. JOSAM recommends the tank probe be cleaned every time the grease is emptied from the interceptor tank. As a minimum, the tank probe should be cleaned every 3 months.
- Concrete Interceptor Probe cleaning can be accomplished by wiping the probe with a soft cloth or sponge. A degreaser (i.e. dish washing soap, etc.) may also be used.

Note: Do not use an abrasive material (i.e. scouring pad, steel wool, etc.) to clean the tank probe as this may damage the tank probe protective covering. Do not bend the tank probe during cleaning.

- Recalibration of the system is not typically required after the Concrete Interceptor Tank Probe Assembly has been cleaned. JOSAM recommends that system calibration be performed once a year.

NOTE:

TO MAINTAIN SYSTEM PERFORMANCE AND ACCURACY IT IS NECESSARY TO REMOVE SOLIDS ACCUMULATION IN THE TANK ON A REGULAR BASIS.

Appendix I

(Not Used)

Appendix II Optional Alarm Unit

TBD

Appendix III Optional Modem Unit

Optional Modem Unit Installation

The following items are provided with EGOLD1000 installation kit when the Optional Modem Unit is provided:

- An external Modem Unit including installation and operating procedures.
- A U.L. approved wall mount low voltage power module.
- A cable to interconnect the Modem Unit to the wall mounted Control Unit.
- A telephone cable to connect the Modem unit to the telephone line.

Install the Modem Unit as follows:

- 1) Find a location that is within 15 feet of the Control Unit, within 5 feet of an 115VAC wall outlet and within 5 feet of a telephone jack to place the Modem Unit provided.
- 2) Plug the jack connector of the modem cable provided into the Control unit and the “D” connector of the modem cable into the rear of the Modem Unit.
- 3) Plug the telephone cable into the “line” connector on the rear of the Modem Unit and the telephone jack.
- 4) Plug the power module provided into the wall and plug the power module cord into the Modem Unit.
- 5) Turn the Modem Unit ON as indicated in the operating procedures provided.
- 6) Cycle the power to the Control Unit. The “RX” and “TX” indicators on the Modem Unit should flicker. Note: This indicates the Control unit is communicating to the Modem Unit.
- 7) Contact JOSAM when the installation is complete. JOSAM will perform a test of the remote grease level monitoring function.