

C SERIES NON-CLOG STRAINER with Integral Bucket

APPLICATION

For use in areas subject to the accumulation of debris on the floor, which may cause the drain line to clog and where pedestrian traffic is expected such as public rest rooms. Bucket is easy to remove and clean.

Available Options

- 2 Satin Finish Bronze Top
- VP Secured Grate, Vandal-Proof Screws

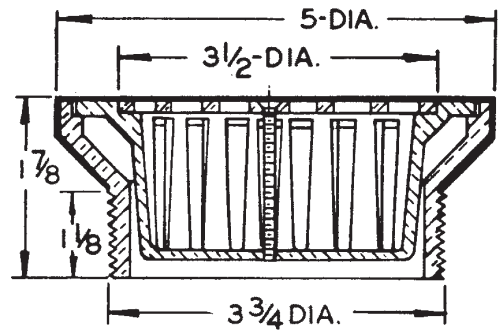

TYPE NO.	FREE AREA	LBS.
5C	4.5	3

D SERIES ROUND NIKALOY DOME STRAINER

APPLICATION

For use in gutters and recessed areas where excessive debris build-up is expected such as laundry rooms. Dome ensures drainage even when partly covered.

Available Options

- 2 Satin Finish Bronze
- 80 Perforated Stainless Steel Basket
- J Backwater Valve
- VP Secured Dome, Vandal-Proof Screws

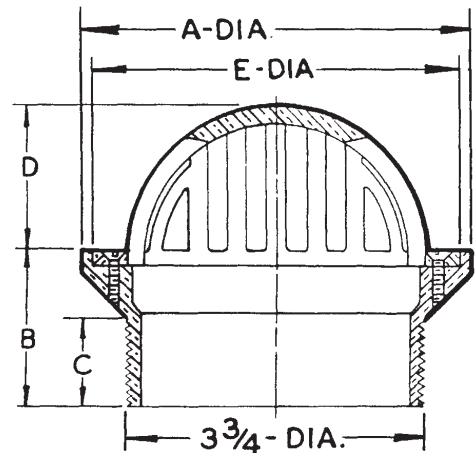

TYPE NO.	A	B	C	D	E	FREE AREA	LBS.
5D	5	1-7/8	1	1-7/8	4-3/4	8.1	2
6D	6	2-1/4	1	1-3/4	5-1/4	8.1	3

E SERIES ROUND NIKALOY TRACTOR STRAINER

APPLICATION

For use in finished floors where medium-weight wheeled loads are anticipated and a "tractor" type non-tilt grate is desired, such as commercial kitchens.

Available Options

- 2 Satin Finish Bronze
- 80 Perforated Stainless Steel Basket
- 93 Cast Iron Strainer, 7E
- J Backwater Valve
- VP Secured Grate, Vandal-Proof Screws

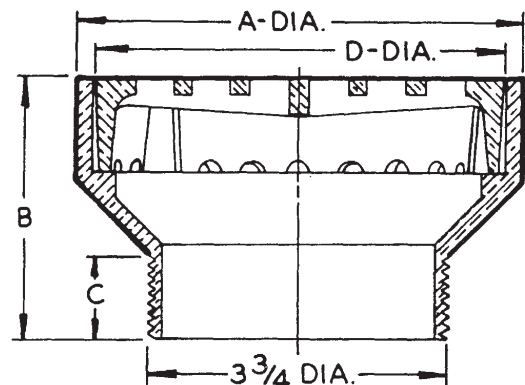

TYPE NO.	A	B	C	D	FREE AREA	LBS.
6E	6	3-3/8	1	5-1/4	6.7	5
7E	7	3	1-1/8	6-1/2	12.0	6
9E	9	3-1/8	7/8	8-1/4	21.2	11