

## 32100 SERIES

## SUPER-FLO® 9" TOP

### APPLICATION

For use in moderate traffic areas such as automobile garages for any type of floor construction where a small to medium flow of liquid is anticipated.

### SPECIFICATION

JOSAM 32100 Series coated cast iron Floor Drain, two-piece body with double drainage flange, WEJLOC® non-puncturing flashing collar, weepholes, bottom outlet, round top, medium-duty loose-set anti-tilting SUPER-FLO® grate with perimeter drainage slots.

### Available Options

▼ -AE	LEVELEZE® Adjustable Extension	-ARE	Acid-Resisting Epoxy
▼ -81	Slotted Cast Iron Bucket	-44	Fixed Extension Collar, Cast Iron (Specify Hgt.), 3" Std.
▼ -TG	Tractor Grate	-44-92	Fixed Extension Collar, Galv. (Specify Hgt.), 3" Std.
▼ -LC1	Locking Cover, Satin Finish Nikaloy	-49	3/4" Primer Tap
-LC2	Locking Cover, Satin Finish Bronze	-50	1/2" Primer Tap
-1	Satin Finish Nikaloy Top	-84	Stainless Steel Mesh Bucket Liner
-2	Satin Finish Bronze Top	-88	Supplementary Strainer
-7	Ductile Iron Grate	-92	Galvanized Cast Iron Parts
-11	Extra-Heavy Grate, Cast Iron		
-13	Dome Grate, Cast Iron	<b>OUTLETS:</b>	
-13-1	Dome Grate, Nikaloy	-66	No-Hub Side Outlet
-13-2	Dome Grate, Bronze	-T	Threaded Outlet
-15	Chained Grate	-X	Inside Caulk Outlet
▼ -39	Solid Cast Iron Cover	-Y	Hub Outlet with Gasket
-VP	Secured Grate, Vandal-Proof Screws	-Z	No-Hub Outlet

- 32100 SLOT WIDTH 3/8"
- 32100-1 SLOT WIDTH 3/16"
- 32100-2 SLOT WIDTH 3/16"

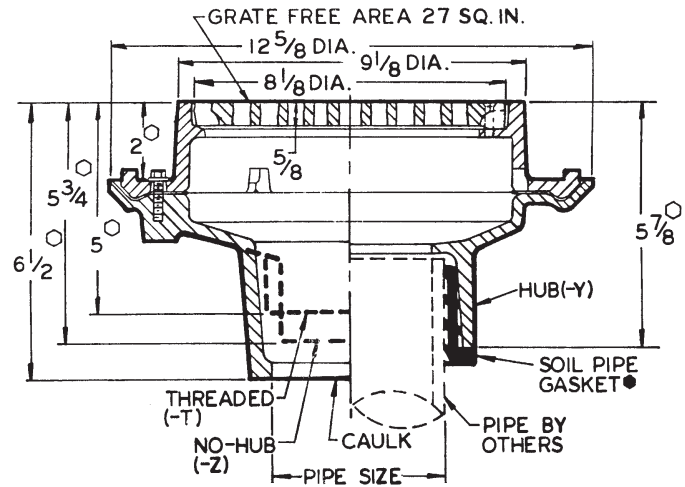

- ADD 1/4" WHEN FURNISHED WITH NIKALOY OR BRONZE TOP.
- CONFORMS WITH ASTM-C564.

FOR OUTLET TYPE SPECIFY -T, -X, -Y or -Z

TYPE NO.	PIPE SIZE	LBS.
32102	2	18
32103	3	21
32104	4	21

## 32100-39 SERIES

## with -39 Solid Cast Iron Cover

### APPLICATION

For use in unfinished floors subject to medium-duty traffic where access to drain outlet is limited by removable solid cover. Useful in regulating small solids into drain line.

### SPECIFICATION

JOSAM 32100-39 Series coated cast iron Floor Drain with double drainage flange, weepholes, bottom outlet and 9" round solid scoriated cast iron cover.

OPTIONS N/A:  
-81, -84

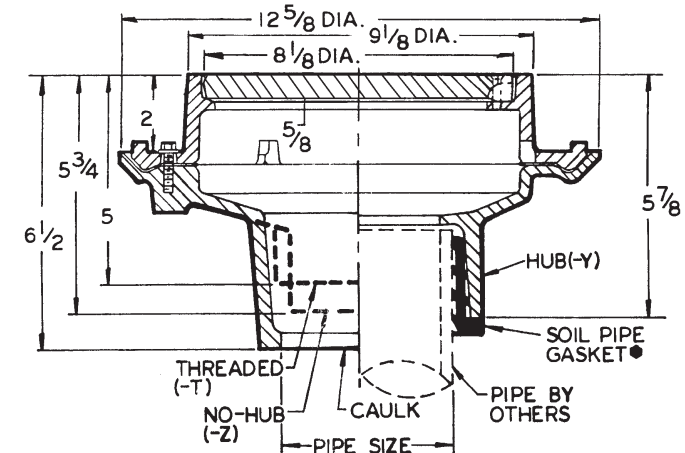

- CONFORMS WITH ASTM-C564.

FOR OUTLET TYPE SPECIFY -T, -X, -Y or -Z

TYPE NO.	PIPE SIZE	LBS.
32102-39	2	22
32103-39	3	25
32104-39	4	25

FLOOR DRAINS

## 32100-81 SERIES with -81 Slotted Cast Iron Bucket

APPLICATION		
For use in medium traffic areas, such as commercial auto garages, for any type of floor construction where a medium to large flow of liquid is anticipated and a bucket is necessary to collect debris which may clog the waste line.		
SPECIFICATION		
JOSAM 32100-81 Series coated cast iron Floor Drain, two-piece body with double drainage flange, WEJLOC® non-puncturing flashing collar, weepholes, bottom outlet, round top, and removable sediment bucket which supports a medium-duty loose-set anti-tilting SUPER-FLO® grate with perimeter drainage slots.		
<b>OPTIONS N/A:</b> -11, -13, -13-1, -13-2, -39 -LC1, -LC2	32100-81 32100-81-1 32100-81-2	SLOT WIDTH 1/2" SLOT WIDTH 3/16" SLOT WIDTH 3/16"
TYPE NO.	PIPE SIZE	LBS.
30002-81	2	22
30003-81	3	24
30004-81	4	25

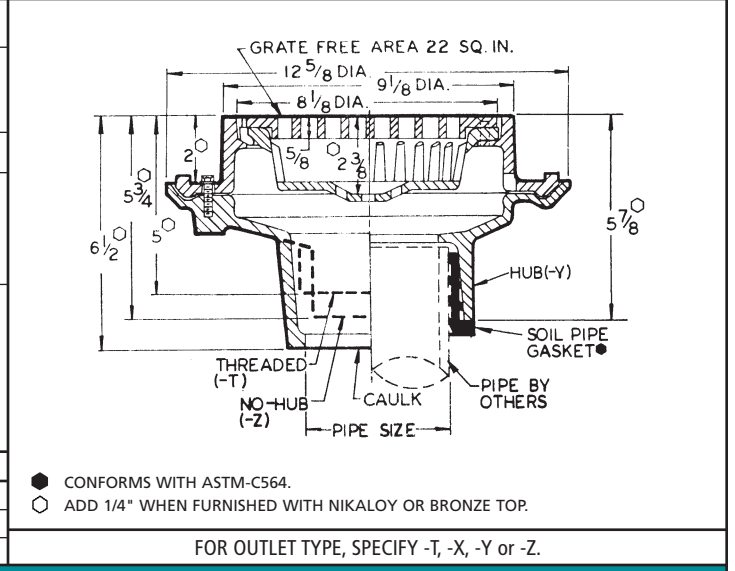

## 32100-AE SERIES with -AE LEVELEZE® Extension

APPLICATION		
For use in moderate traffic areas, such as automobile garages, for any type of floor construction where a small to medium flow of liquid is anticipated. LEVELEZE® adjustable collar permits accurate positioning of grate to meet finished floor level.		
SPECIFICATION		
JOSAM 32100-AE Series coated cast iron LEVELEZE® Floor Drain, two-piece body with double drainage flange, WEJLOC® non-puncturing flashing collar, weepholes, bottom outlet, round top, adjustable collar with rolled thread and loose-set, anti-tilting, medium-duty, SUPER-FLO® grate with perimeter drainage slots.		
<b>OPTION N/A:</b> -11, -44	32100-AE 32100-AE-1 32100-AE-2	SLOT WIDTH 3/8" SLOT WIDTH 3/16" SLOT WIDTH 3/16"
TYPE NO.	PIPE SIZE	LBS.
30002-AE	2	31
30003-AE	3	32
30004-AE	4	33

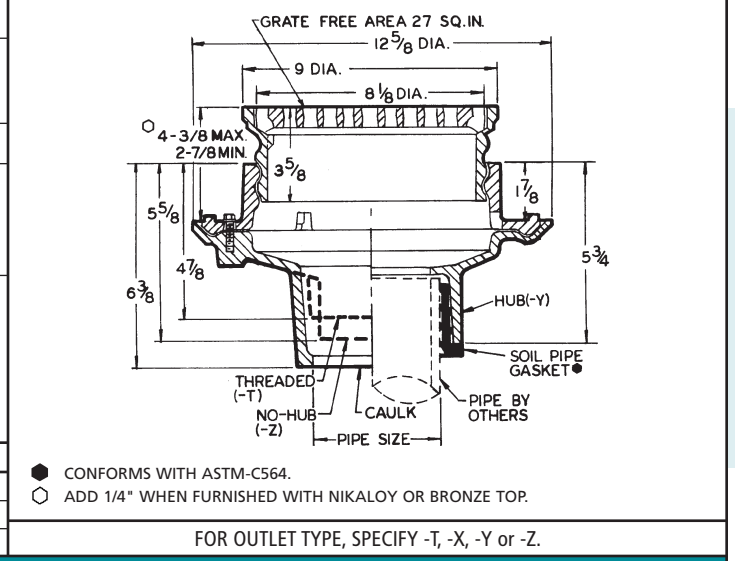

## 32100-AE-81 SERIES with -AE LEVELEZE® Extension & -81 Slotted Cast Iron Bucket

APPLICATION		
For use in moderate traffic areas, such as commercial auto garages, for any type of floor construction where a small to medium flow of liquid is anticipated and a bucket is necessary to collect debris which may clog the waste line. LEVELEZE® adjustable collar permits accurate positioning of grate to meet finished floor level.		
SPECIFICATION		
JOSAM 32100-AE-81 Series coated cast iron LEVELEZE® Floor Drain, two-piece body with double drainage flange, WEJLOC® non-puncturing flashing collar, weepholes, bottom outlet, round top, adjustable collar with rolled thread and removable sediment bucket which supports a medium-duty, loose-set, anti-tilting, SUPER-FLO® grate with perimeter drainage slots.		
<b>OPTIONS N/A:</b> -11, -13, -13-1, -13-2, -39, -44	32100-AE-81 32100-AE-81-1 32100-AE-81-2	SLOT WIDTH 3/8" SLOT WIDTH 3/16" SLOT WIDTH 3/16"
TYPE NO.	PIPE SIZE	LBS.
30002-AE-81	2	34
30003-AE-81	3	34
30004-AE-81	4	34

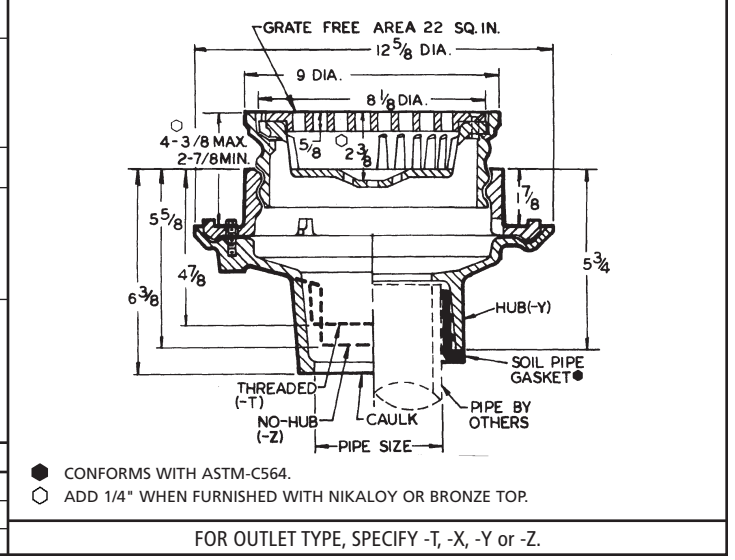

FLOOR DRAINS

## 32100-AE-LC1-88 SERIES w/ LEVELEZE® Ext., Nikaloy Locking Cover & Supl. Strainer

### APPLICATION

For use in pedestrian and light wheel traffic areas where drainage is not a constant factor. Solid hinged key-locking cover prevents intrusion of foreign objects, which may be swept up before cover is opened for wash down. The secondary strainer prevents debris from entering the waste line.

### SPECIFICATION

JOSAM 32100-AE-LC1-88 Series coated cast iron LEVELEZE® Floor Drain, two-piece body with double drainage flange, WEJLOC® non-puncturing flashing collar, weep-holes, bottom outlet, round satin Nikaloy hinged key-locking cover, adjustable collar and internal strainer.

Series 32100-AE-LC2-88 with Bronze Locking Cover

#### OPTIONS N/A:

-7, -11, -13, -13-1, -13-2, -15, -39, -44, -84

TYPE NO.	PIPE SIZE	LBS.
32102-AE-LC1-88	2	31
32103-AE-LC1-88	3	32
32104-AE-LC1-88	4	33

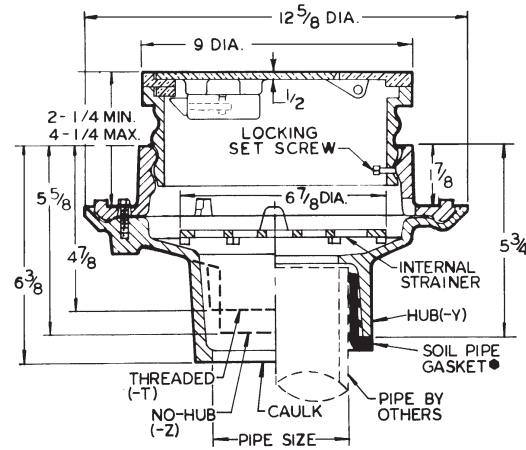

● CONFORMS WITH ASTM-C564.

FOR OUTLET TYPE, SPECIFY -T, -X, -Y or -Z.

## 32100-AE-TG SERIES with -AE LEVELEZE® Extension & -TG 9" Tractor Top

### APPLICATION

For use in heavy traffic areas, such as warehouses, for any type of floor construction where a small to medium flow of liquid is anticipated. LEVELEZE® adjustable collar permits accurate positioning of grate to meet finished floor level.

### SPECIFICATION

JOSAM 32100-AE-TG Series coated cast iron LEVELEZE® Floor Drain, two-piece body with double drainage flange, WEJLOC® non-puncturing flashing collar, weep-holes, bottom outlet, round top, adjustable collar with rolled thread and heavy-duty, deep-set tractor grate.

#### OPTIONS N/A:

-11, -13, -13-1, -13-2, -39, -44, -81, -84

32100-AE-TG	SLOT WIDTH 1/2"
32100-AE-TG-1	SLOT WIDTH 7/16"
32100-AE-TG-2	SLOT WIDTH 7/16"

TYPE NO.	PIPE SIZE	LBS.
32102-AE-TG	2	33
32103-AE-TG	3	35
32104-AE-TG	4	37

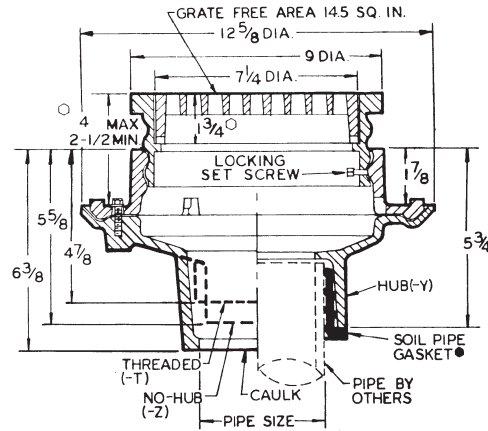

● CONFORMS WITH ASTM-C564.

○ ADD 1/4" WHEN FURNISHED WITH NIKALOY OR BRONZE TOP.

FOR OUTLET TYPE, SPECIFY -T, -X, -Y or -Z.

## 32100-TG SERIES with -TG 9" Tractor Top

### APPLICATION

For use in heavy traffic areas such as garages and loading docks for any type of floor construction where a small to medium flow of liquid is anticipated.

### SPECIFICATION

JOSAM 32100-TG Series coated cast iron Floor Drain, two-piece body with double drainage flange, WEJLOC® non-puncturing flashing collar, weep-holes, bottom outlet, round top and heavy-duty, loose-set tractor grate.

#### OPTIONS N/A:

-11, -13, -13-1, -13-2, -39, -81, -84,

SLOT WIDTH 3/8"

TYPE NO.	PIPE SIZE	LBS.
32102-TG	2	25
32103-TG	3	26
32104-TG	4	27

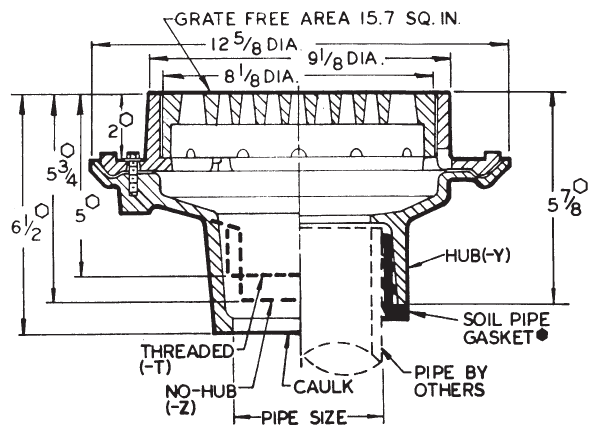

● CONFORMS WITH ASTM-C564.

○ ADD 1/4" WHEN FURNISHED WITH NIKALOY OR BRONZE TOP.

FOR OUTLET TYPE, SPECIFY -T, -X, -Y or -Z.