

MANUAL FL-3

INSTALLATION INSTRUCTIONS

JOSAM

UNITRON[®]

**LAVATORY, SINK,
URINAL & COOLER
CARRIERS**

**USE THIS MANUAL AS A SUPPLEMENT
TO CATALOG SUBMITTAL DRAWINGS**

**JOSAM COMPANY
Michigan City, Indiana 46360**

REPRESENTATIVES IN ALL PRINCIPAL CITIES

INSTALLATION INSTRUCTIONS

JOSAM "UNITRON" CARRIERS

FOR MEN'S URINALS, LAVATORIES, SINKS

TYPE CARRIER					ONLY CERTAIN STEPS ARE NECESSARY FOR INSTALLING THE VARIOUS TYPES OF CARRIERS LISTED AT THE LEFT: IN THE ORDER SHOWN, FOLLOW THE DIRECTIONS OPPOSITE THE CHECK MARKS INDICATING THE SPECIFIC CARRIER TO BE INSTALLED.	See Fig. No.
Concealed Arms		Hanger Plate	Exposed Arms			
Floor Mounted	Wall Mounted		Floor Mounted	Wall Mounted		
✓		✓	✓		Insert upright pipes in feet and secure.	1
✓		✓	✓		Locate and anchor feet to base floor	1
✓			✓		Assemble tie rod and headers on upright pipe with "U" Bolts, hand tight.	2 3
	✓			✓	Assemble adjustable wall plates, adjust and secure.	4
		✓			* Assemble supporting, or supporting and bearing plates to upright pipes with "U" bolts, hand tight.	5
✓	✓				Assemble adjustable extensions with locknuts to headers or wall plate with set screws on top. Adjust and secure. If desired, arms may be removed from extensions during construction.	2 8 10
			✓	✓	Assemble arm bolts with nuts and washers, into headers or wall plate. Adjust and secure.	3
		✓			* Assemble bolts and washers to plate(s) adjust and secure.	5
✓			✓		Adjust right-hand header to proper height and secure to upright pipe and tie rod. Level left-hand header using adjustable extensions or arm bolts and secure to upright pipe and tie rod.	2 3
	✓			✓	Attach carrier to wall at proper height and secure.	
		✓			* Adjust and level plate(s) to proper height and secure.	5
✓	✓	✓	✓	✓	Complete wall and floor construction around carrier.	
✓	✓				If previously removed, re-insert arms into extensions with tandem keeper in groove. Adjust and secure arms.	6
					If escutcheons are specified, slip around arm, press firmly to wall, secure to adjustable extension.	10
✓	✓				Adjust tandem keepers with leveling screws to proper locations on arms and secure. Set fixture in proper location on arms and secure.	7 8
			✓	✓	Assemble arms with leveling screws to arm bolts. Adjust, level and secure.	
		✓			Assemble hanger(s), if required, onto carrier. Adjust and secure.	
✓	✓		✓	✓	Set fixture on arms and level.	
		✓			Set fixture on hanger(s) and/or supporting bolts. Secure in place.	
✓	✓				Secure fixture by tightening screw of fixture locking device, thereby forcing against inside bottom of fixture and parallel to arms.	8
			✓	✓	Secure fixture in place by inserting toggle bolt, with oversized washer, through slot in arm and opening in bottom of fixture. Tighten toggle bolt.	9

FOR CARRIERS EQUIPPED WITH STD. PLATES SEE MANUAL SP-1 (PACKED W/CARRIER) FOR FURTHER DETAILS.

The following diagrams illustrate parts which are included in many types of Josam Carriers. However, all parts indicated do not necessarily apply to all carriers.

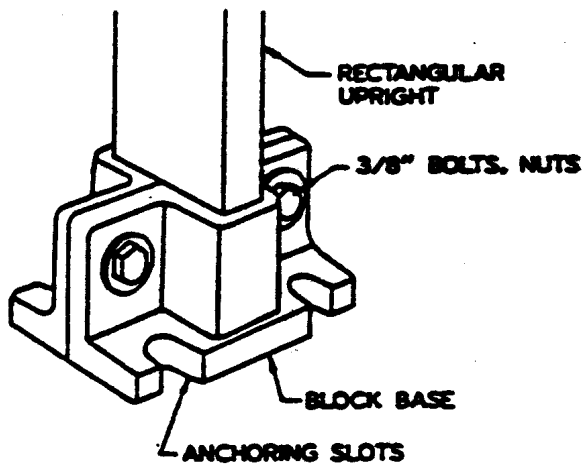
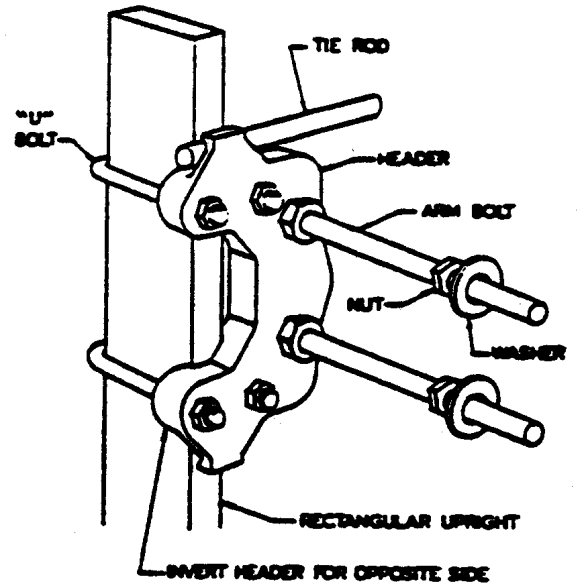

FIGURE NO. 1



EXPOSED ARM
FIGURE NO. 3

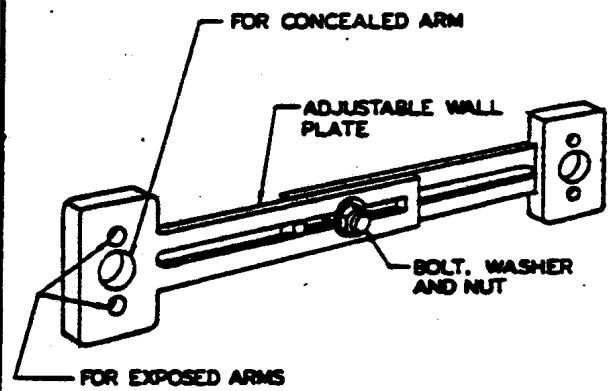
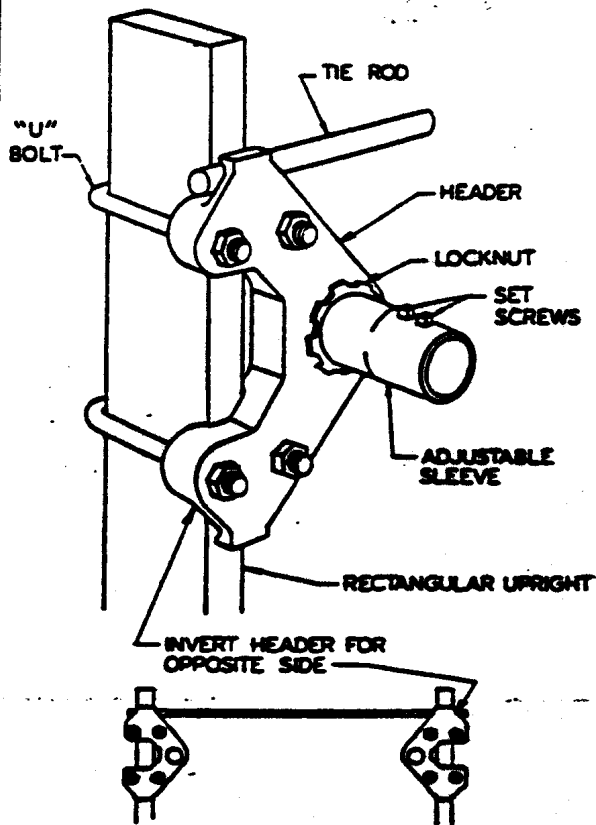

FIGURE NO. 4



CONCEALED ARM

FIGURE NO. 2

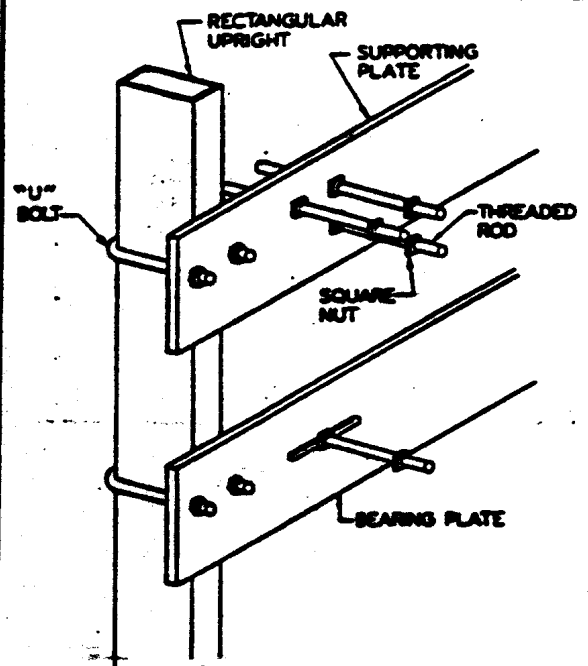
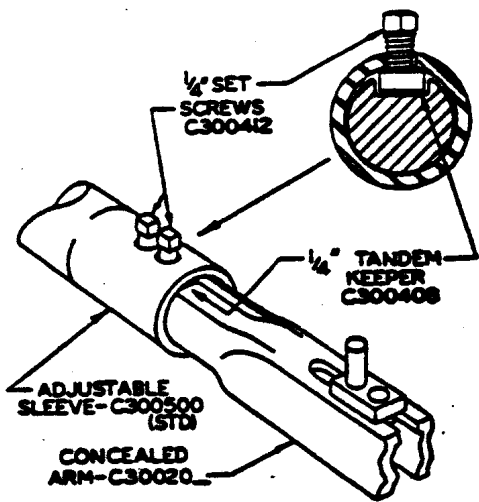

FIGURE NO. 5



**CONCEALED ARM
& SLEEVE ASSEMBLY**
FIGURE NO. 6

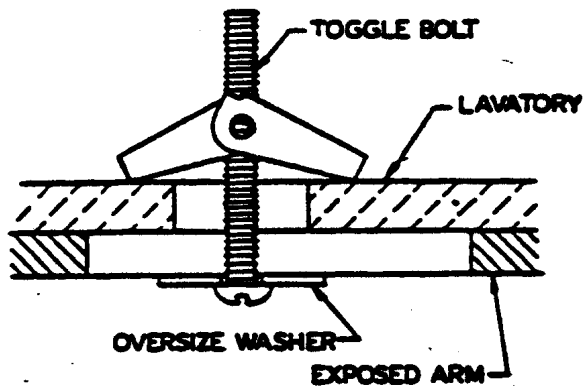

FIGURE NO. 9

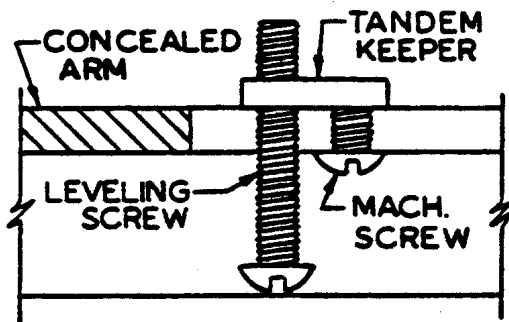

FIGURE NO. 7

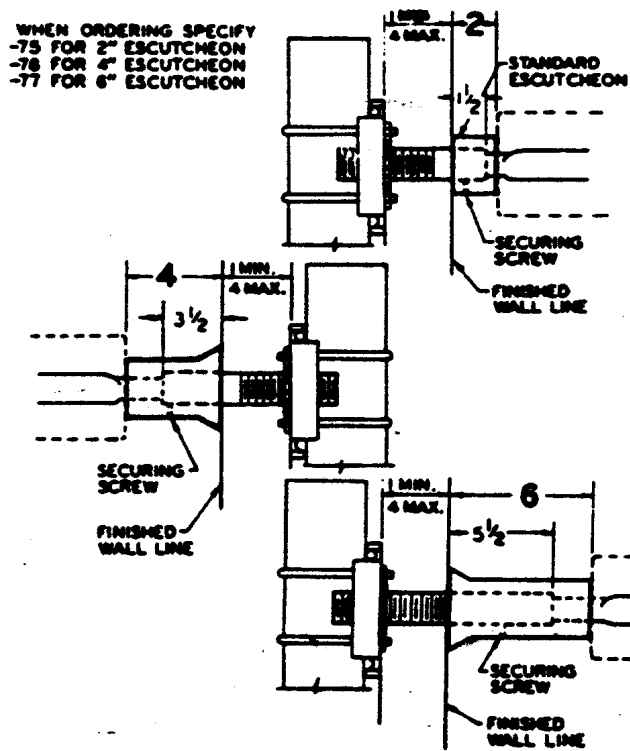

FIGURE NO. 10

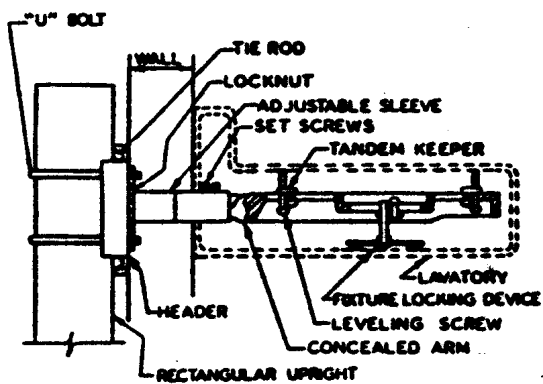

FIGURE NO. 8