

For frost-free hydrants,
see HYDRASAN I Models
71000 and 71050.

MILD CLIMATE HYDRASAN® I

JOSAM MODELS 71020 and 71070 COMBINATION MILD CLIMATE HYDRANTS WITH VACUUM BREAKER-BACKFLOW PREVENTER AND PRESSURE RELIEF VALVE

— INSTRUCTIONS —

INSTALLATION OPERATION MAINTENANCE

CAUTION: Do not destroy this form — Leave with owner.

You have one of the finest mild climate hydrants available, JOSAM HYDRASAN I. Adherence to these instructions will ensure satisfactory installation and proper performance. Take a moment to read them now.

INSTALLATION

A. Model 71020 Assembly

If your hydrant is the box type (Model 71020), it will be necessary to assemble the wall box to the hydrant before proceeding with the installation. Open box cover using Control Key (1). Insert hydrant, inlet end first, through opening in box bottom. Be sure outlet (hose connection) is at right as you face box with cover hinged at top. With hydrant head flange seated in recess surrounding hole in box, secure hydrant in place by tightening the two set screws, in tabs or box bottom, against hydrant head.

B. Model 71020 and 71070 Installation

HYDRASAN I is installed, with head horizontal, outlet to right, in the manner typical to all mild climate hydrants. The face (front) of hydrant or hydrant wall box (with cover hinged at top) must be set with flange against finished wall overlapping wall opening provided for the hydrant. The hydrant must be level (plumb) and extend into or through the wall with inlet in or inside of wall. Grout the hydrant (and box) securely in place with mortar. Follow normal plumbing practice to make inlet connection. NOTE: This sequence may vary depending on job conditions. Refer to Figures 1 and 2.

BE SURE TO LEAVE CONTROL KEY AND HEX. KEYS 3/32" and 5/32" WITH OWNER.

CAUTION

If solder (sweat) connections are used, heat must be controlled to avoid damage to non-metallic hydrant components. For best results, remove pressure assist seal assembly (parts 4, 5, and 15) prior to soldering joint. Allow to cool before re-inserting pressure assist seal.

Before hydrant is put into service, water supply system must be flushed thoroughly to remove dirt and chips that could cause hydrant malfunction. Remove pressure assist seal assembly prior to flushing.

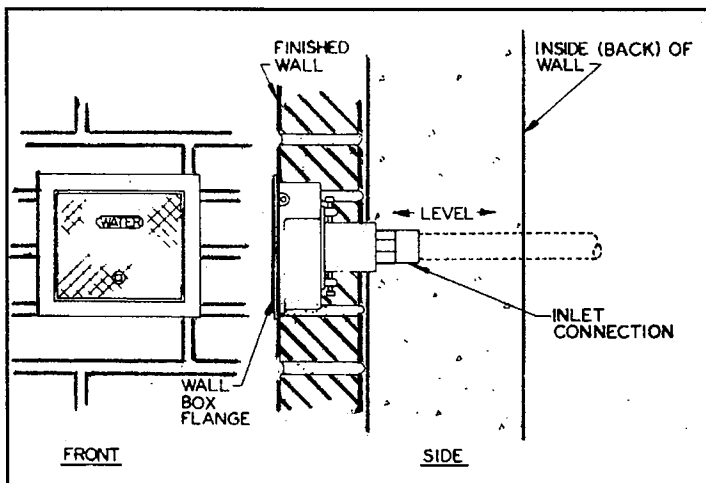

HYDRASAN I 71020 INSTALLATION
FIGURE 1

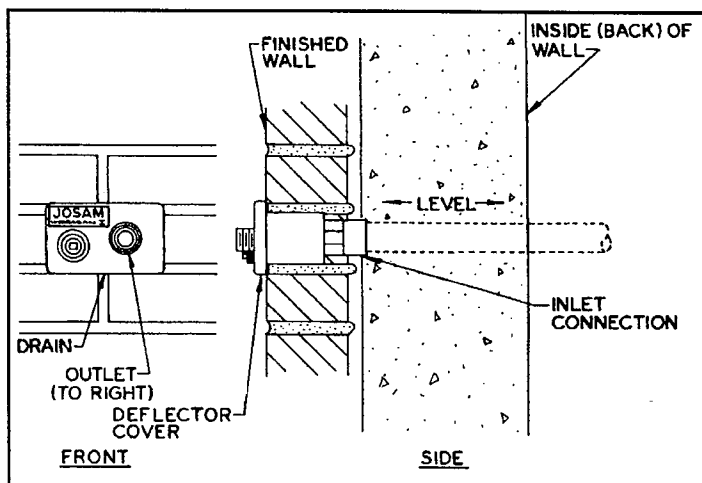

HYDRASAN I 71070 INSTALLATION
FIGURE 2

OPERATION

Refer to Figure 3 for identification of parts and features mentioned in these instructions.

A. ON-OFF

HYDRASAN I is turned on and off by Control Key (1). Rotate the key counterclockwise (left turn) to turn hydrant on and clockwise (right turn) to turn it off. Built-in stops prevent over-opening and over-closing. Some drainage after hydrant is turned off will be noted at outlet (hose connection) and Deflector Cover Drain (26). This is typical of mild climate hydrants and is not cause for alarm. NOTE: In the unlikely event of continuous drainage, it is a signal that service is necessary. This is covered in the Maintenance Section.

B. PRESSURE RELIEF

If a hose is attached at the time hydrant is turned off, and there is no nozzle on the hose, or if the nozzle is open, the hose will drain; however, if the nozzle is closed, the hose will not drain, but the pressure in the hose and hydrant will be relieved, dissipating through the Vent and Drain Ports (24) and Vacuum Breaker Ports (33), at which time there will be a momentary spurt of water from these ports.

C. VACUUM BREAKER-BACKFLOW PREVENTER

If for any reason a backflow condition should develop in the attached hose, i.e., pressure imbalance due to sudden supply pressure drop below outlet pressure, the Vacuum Breaker Seal (29) will instantly respond opening Air Ports (33), to break any vacuum and sealing against Piston (31) to prevent backflow from the attached hose and protect the water supply system from entry of contaminants.

D. BOX TYPE — MODEL 71020

Control Key (1) locks and unlocks the box. Do not store the key in the box. The cover should be kept closed and locked at all times when the hydrant is not being used. When hydrant maintenance is required, cover can be adjusted to stay open by sliding it back into the box on its slotted hinge lugs when it is opened to the horizontal position.

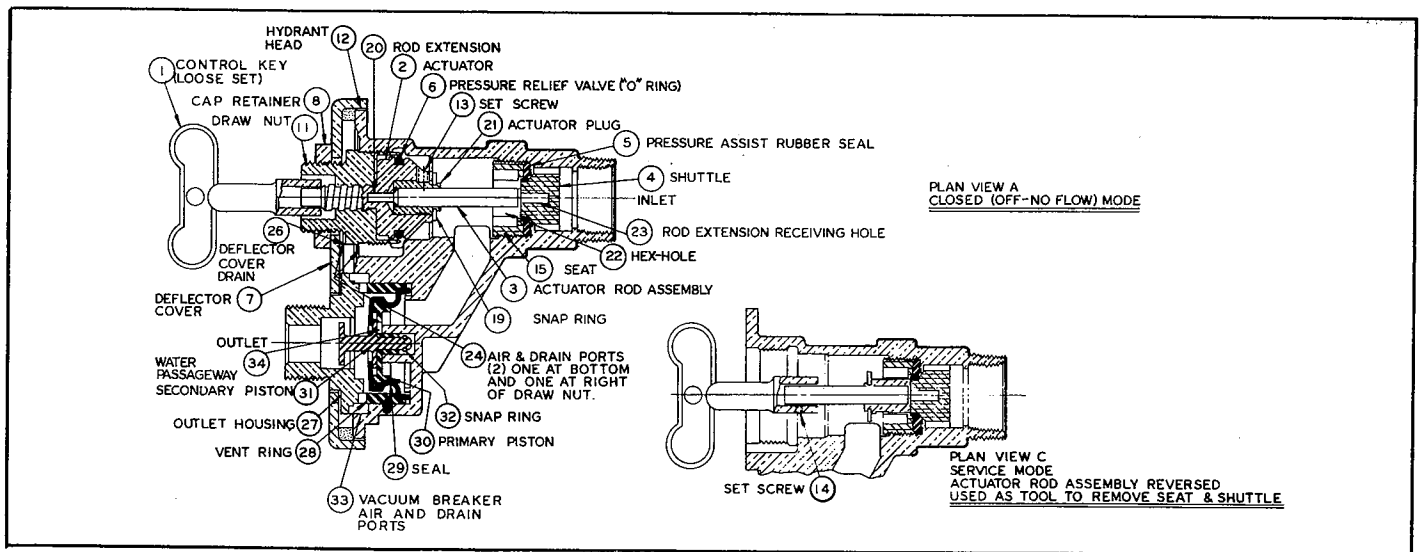

FIGURE 3

MAINTENANCE

HYDRASAN®I will seldom require service. However, continuous drainage from the outlet is a signal that inspection and possible replacement of certain parts are in order. A self-contained tool, Actuator Rod (3), when reversed, makes the job easy. The procedure for removal and replacement of hydrant sealing parts is as follows:

A. Shut off water in supply line to hydrant, and turn hydrant on to relieve pressure.

B. Use pliers. Firmly grip Cap Retainer (8) and turn counterclockwise to remove it, then remove Deflector Cap (7). Shut off hydrant as tight as possible with Control Key (1) and use an adjustable open end wrench or channel-lock type pliers to "break" Draw Nut (11) loose, then remove it with Control Key (1), turning counterclockwise until threads are free from Hydrant Head (12). Grasp Draw Nut (11) firmly and pull toward you to remove Actuator (2) and Actuator Rod (3). See Figure 4.

C. Loosen Set Screw (13) with a $\frac{3}{32}$ " hex. key and separate Actuator (2) from Actuator Plug (21) on end of Actuator Rod (3). See Figure 5.

D. Reverse Actuator Rod (3) and insert into hydrant as far as possible, using Control Key (1) secured to Actuator Rod (3) with Set Screw (14). With Actuator Plug (21) (hex.) on end of Actuator Rod (3) inserted in Hex. Hole (22) in Seat (15), which places Rod Extension (20) in Hole (23) in Shuttle (4), firmly rotate Control Key (1) counterclockwise to unscrew Seat (15) and pull out entire Valve (15, 5 and 4). See Figures 3, 6, and 7.

E. Replace worn parts with new parts as required. Reassemble hydrant, reversing the procedure in Steps A through D to place it back in service. Be sure to make Cap Retainer (8) tight to prevent tampering.

NOTE: If pressure relief Valve "O" Ring (6) appears worn, it should be replaced when hydrant is apart. This part can be checked and, if necessary, replaced without turning off water supply to hydrant because the Pressure Assist Seal (Parts 4, 5, and 15) prevents any water from entering. This feature makes possible removal of all parts downstream (in front) of the Seal (or Valve) with water supply on.

Should it ever be necessary to service the Vacuum Breaker-Backflow Preventer in the outlet of HYDRASAN I, the procedure for removal and replacement of operating parts is as follows:

F. After Deflector Cover (7) has been removed (see Maintenance Step B), remove the four housing retaining screws with a $\frac{5}{32}$ " hex. key and take off Outlet Housing (27). Lift out Vent Ring (28) and operating parts, Seal (29) Primary and Secondary Pistons (30 and 31). Inspect for wear.

G. Replace worn parts with new parts as required. Reassemble Vacuum Breaker-Backflow Preventer, reversing the procedure in Step F to place it back in service.

Service kits containing all parts necessary for this maintenance can be obtained through your plumbing supply dealer

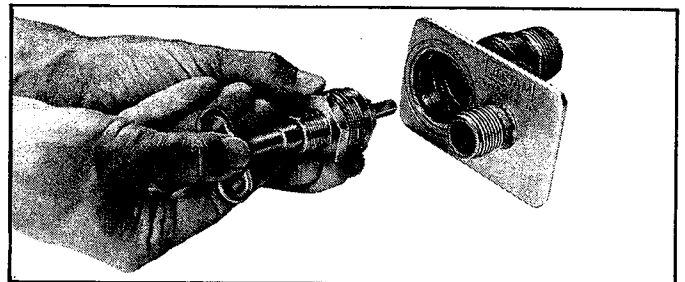

FIGURE 4

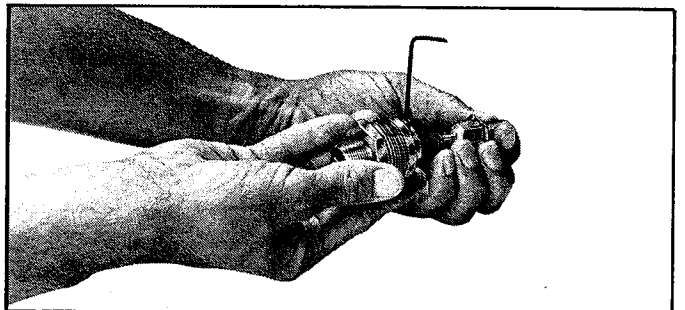

FIGURE 5

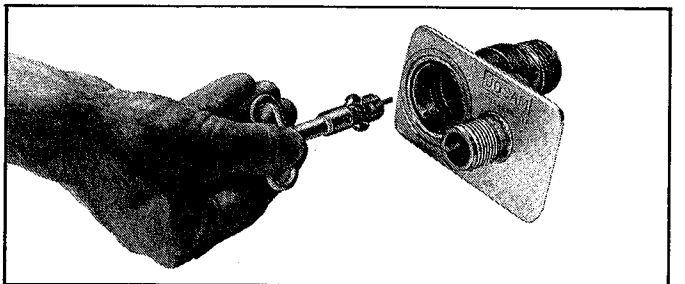

FIGURE 6

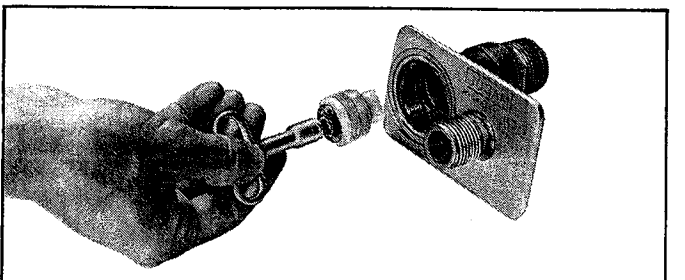

FIGURE 7