

**SPECIFICATION:**

JOSAM SERIES 17550 FLOOR-MOUNTED, SINGLE LAVATORY CARRIER WITH HANGER PLATE, ADJUSTABLE SUPPORTING RODS, STRUCTURAL UPRIGHTS AND WELDED FEET. DESIGNED TO SUPPORT CAROMA CUBE URINAL.

**LAVATORY CARRIER**

**FLOOR-MOUNT  
HANGER PLATE**

SERIES **17550-M1704**

RECOMMEND FEET BE SUCURED TO FLOOR WITH 1/2" BOLTS AND ANCHORS BY OTHERS

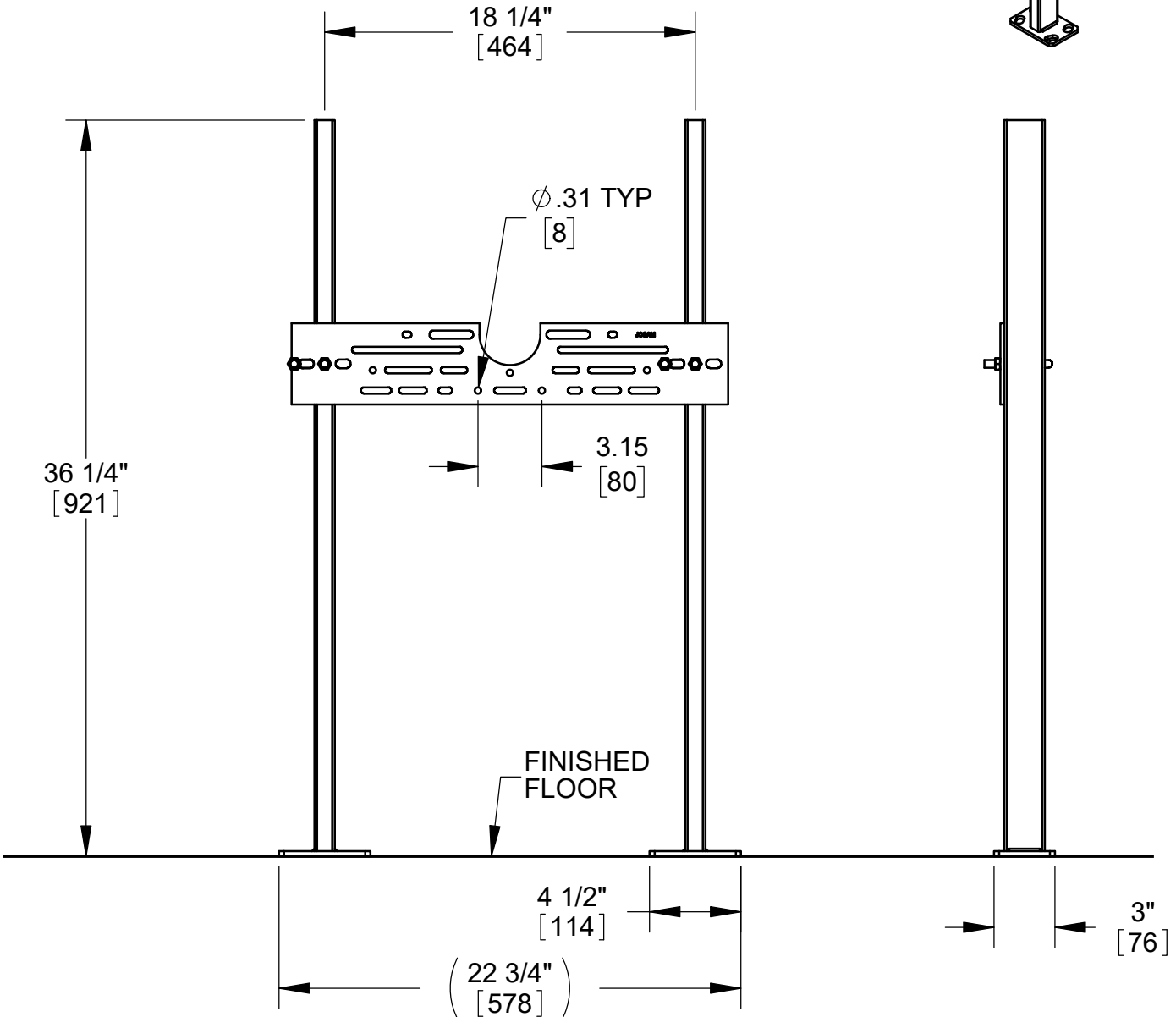
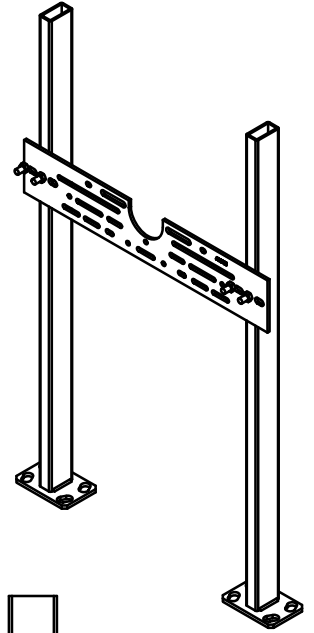

WARNING: Cancer and Reproductive Harm - www.P65Warnings.ca.gov

DATE OF LAST CHANGE: 06/05/18

DIMENSIONS ARE SUBJECT TO MANUFACTURERS TOLERANCES AND CHANGE WITHOUT NOTICE. WE CAN ASSUME NO RESPONSIBILITY FOR USE OF SUPERSEDED OR VOID DATA.



MICHIGAN CITY, INDIANA

NOTES