

SPECIFICATION:

JOSAM SERIES 88240 TRAP GUARD INSERT TO PROVIDE A WATERLESS TRAP SEAL AGAINST ODORS AND PESTS.

ASSE 1072, ICC, UPC

**TRAP GUARD
INSERT**

SERIES **88240**

PRODUCT COMPLIES WITH CALIFORNIA PROPOSITION 65 REQUIREMENTS.

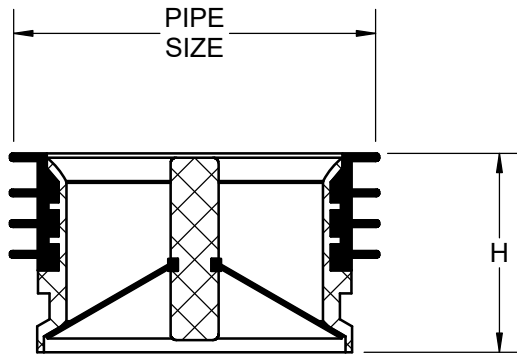
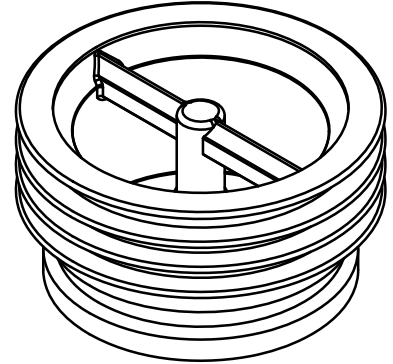
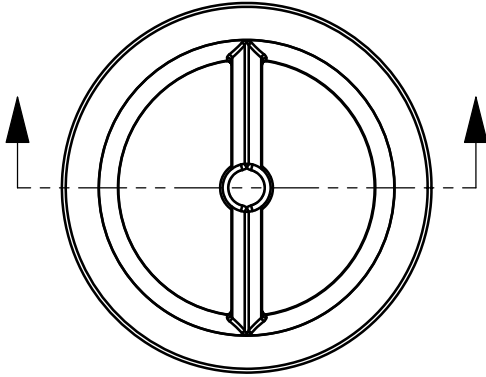

	PIPE SIZE	MODEL	H
	2"	88242	2 [51]
	3"	88243	2 [51]
	3-1/2"	88243-1/2*	2 [51]
	4	88244	2 [51]

* FITS JOSAM SERIES 30000 TYPE STRAINER BODY DIAMETER

WARNING: Cancer and Reproductive Harm - www.P65Warnings.ca.gov

DATE OF LAST CHANGE: 10/20/20

DIMENSIONS ARE SUBJECT TO MANUFACTURERS TOLERANCES AND CHANGE WITHOUT NOTICE. WE CAN ASSUME NO RESPONSIBILITY FOR USE OF SUPERSEDED OR VOID DATA.



MICHIGAN CITY, INDIANA

NOTES