

SPECIFICATION:

JOSAM SERIES TD-130 SHALLOW HDPE CHANNEL.

**LITE LINE
TRENCH DRAIN**

SERIES **TD-130**

MAX. CONTINUOUS OPERATING TEMP.: 140° F

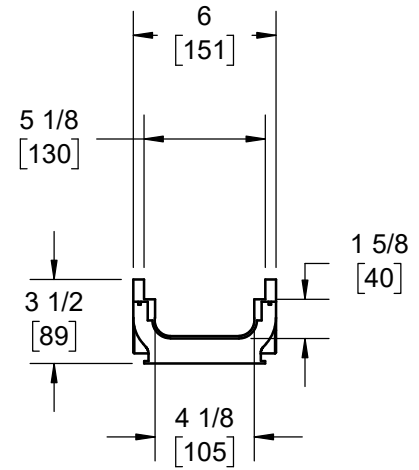
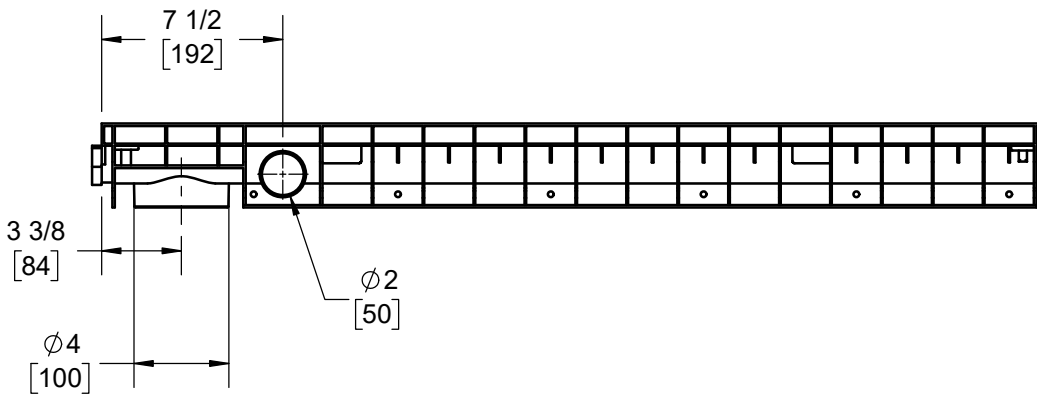
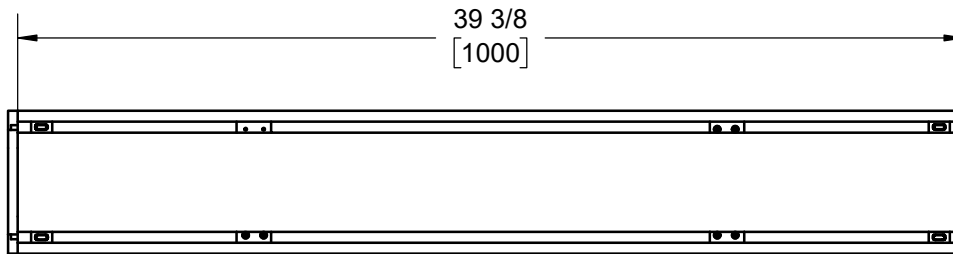
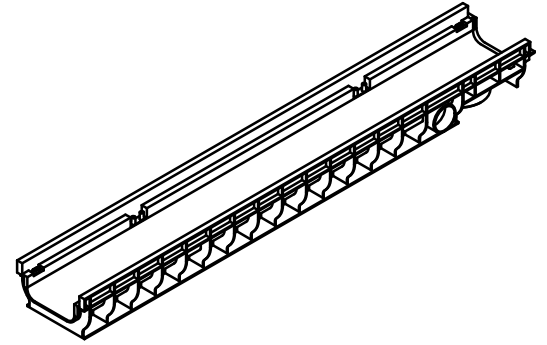

SEE SEPARATE SUBMITTALS:

TD-130-ABS	CHANNEL WITH ABS PERFORATED GRATES AND LOCKS
TD-130-GALV	CHANNEL WITH GALVANIZED STEEL SLOTTED GRATE AND LOCKS
TD-130-SS	CHANNEL WITH STAINLESS STEEL GRATE AND LOCKS
TD-130-CI	CHANNEL WITH CAST IRON GRATES AND LOCKS

WARNING: Cancer and Reproductive Harm - www.P65Warnings.ca.gov

DATE OF LAST CHANGE: 01/14/20

DIMENSIONS ARE SUBJECT TO MANUFACTURERS TOLERANCES AND CHANGE WITHOUT NOTICE. WE CAN ASSUME NO RESPONSIBILITY FOR USE OF SUPERSEDED OR VOID DATA.



MICHIGAN CITY, INDIANA

NOTES