

E1 SERIES

ROUND NIKALOY STRAINER with Extended Rim

APPLICATION

For use in non-traffic areas where the extended rim strainer will contain spills or condensate waste, such as under ice machines. The recessed grate prevents poured liquids from flooding and splashing.

Available Options

- 2 Satin Finish Bronze
- 80 Perforated Stainless Steel Basket
- J Backwater Valve
- VP Secured Grate, Vandal-Proof Screws

TYPE NO.	A	B	C	D	H	FREE AREA	LBS.
6E1	5-3/4	3-3/8	1	5-3/8	1-1/4	4	5
7E1	7-1/8	3	1-1/8	6-3/8	1	8.2	7
9E1	8-7/8	3-1/8	7/8	8-3/8	1-1/2	21.2	9

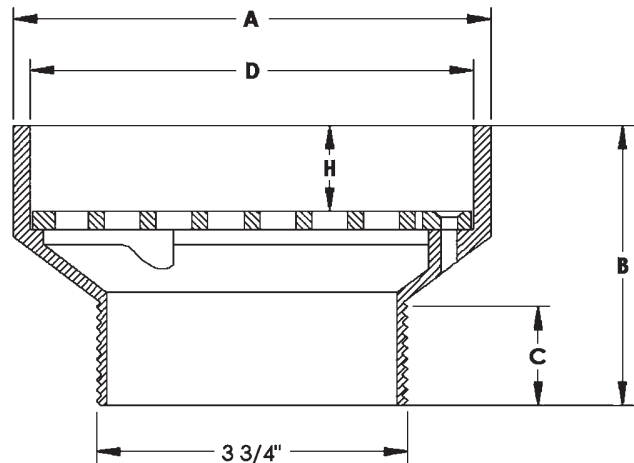

E2 SERIES

ROUND NIKALOY STRAINER with Round Funnel

APPLICATION

For use in non-traffic areas where the round funnel contains condensate drip, and grate openings evacuate liquid spills from the surrounding floor, such as under steam tables.

Available Options

- 2 Satin Finish Bronze
- 80 Perforated Stainless Steel Basket
- J Backwater Valve
- VP Secured Grate, Vandal-Proof Screws

TYPE NO.	LBS.
7E2	8

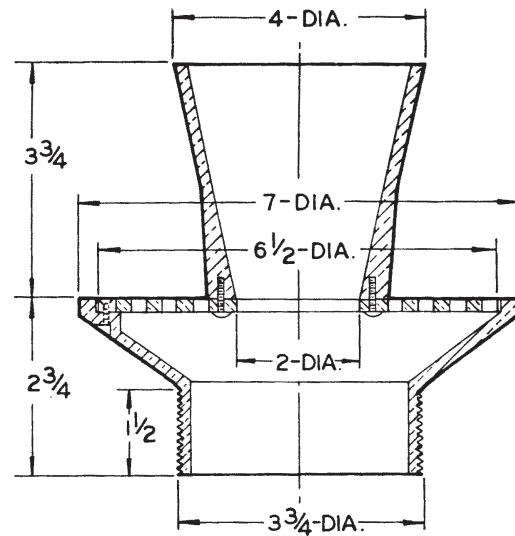

E3 SERIES

ROUND NIKALOY STRAINER with Oval Funnel

APPLICATION

For use in non-traffic areas where the oval funnel contains condensate drip from more than one source, and grate openings evacuate liquid spills from the surrounding floor, such as under commercial kitchen equipment.

Available Options

- 2 Satin Finish Bronze
- 80 Perforated Stainless Steel Basket
- J Backwater Valve
- VP Secured Grate, Vandal-Proof Screws

TYPE NO.	LBS.
7E3	8

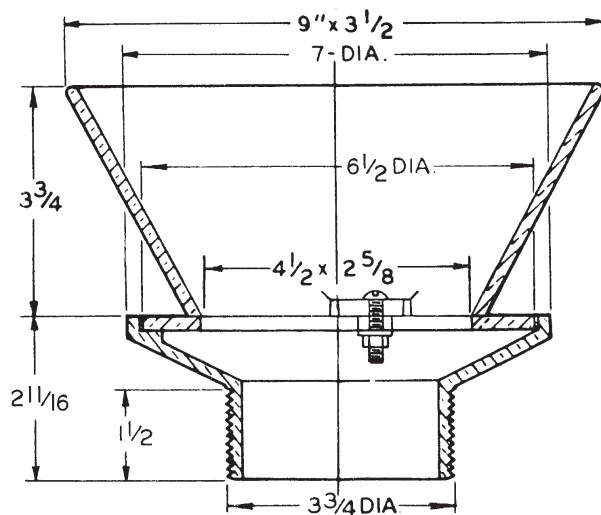

FLOOR DRAINS