

49300 SERIES

SUPER-FLO® 8" SQUARE TOP, 6" DEEP

APPLICATION

For use in non-traffic areas where ultimate sanitation is desired, such as kitchens, hospitals and food processing plants. The 7-1/4" square grate and medium sump accept moderate flow and the dome strainer intercepts debris which could block the drain line. Double drainage flange serves as an anchor in the sub-floor and redirects secondary moisture to the waste line. It may also be used with a clamp device to assure a bond between the drain and the flashing or waterproof membrane.

SPECIFICATION

JOSAM 49300 Series square cast iron 5-7/8" deep SUPER-FLO-SEPTOR® Floor Sink with acid-resisting interior, double drainage flange with weepholes, bottom outlet, aluminum internal dome strainer and cast iron, non-traffic, acid-resisting, anti-tilting, SUPER-FLO® Grate.

For Options, See Below

OPTIONS N/A: -VP, -8, -20, -24

TYPE NO.	PIPE SIZE	LBS
49302	2	24
49303	3	24
49304	4	24

SLOT WIDTH 7/16"

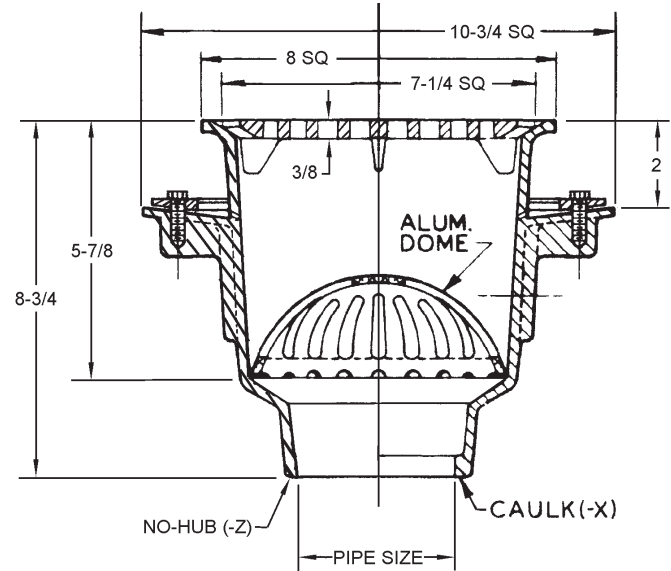

GRATE FREE AREA 21 SQ. IN.

FOR OUTLET TYPE, SPECIFY -X or -Z.

49300-LF SERIES

Less Flange

APPLICATION

For use in non-traffic areas where ultimate sanitation is desired, such as kitchens, hospitals and food processing plants. The 7-1/4" square grate and medium sump accept moderate flow and the dome strainer intercepts debris which could block the drain line.

SPECIFICATION

JOSAM 49300-LF Series square cast iron 5-7/8" deep SUPER-FLO-SEPTOR® Floor Sink with acid-resisting interior, bottom outlet, aluminum internal dome strainer and cast iron, non-traffic, acid-resisting, anti-tilting, SUPER-FLO® Grate.

OPTIONS N/A: -VP, -8, -20, -24, -C

TYPE NO.	PIPE SIZE	LBS
49302-LF	2	20
49303-LF	3	20
49304-LF	4	21

SLOT WIDTH 7/16"

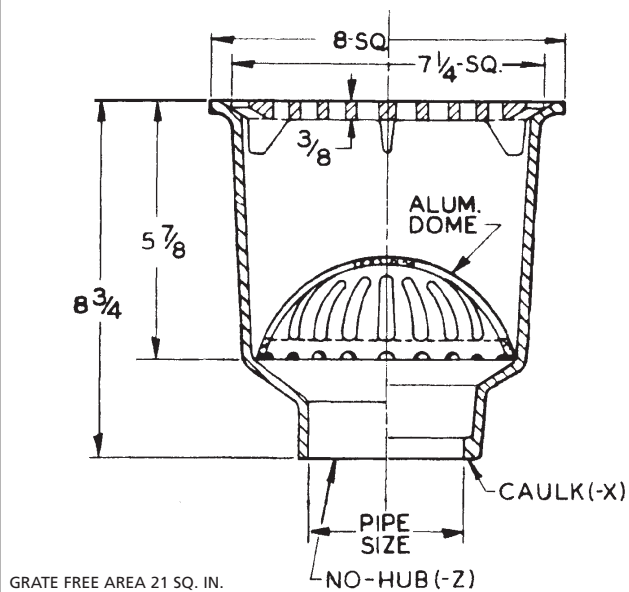

GRATE FREE AREA 21 SQ. IN.

OPTIONS

- | | | | |
|-------|--|----------------|--------------------------------------|
| ▼ -LF | Less Flange | -31 | Sediment Bucket (Aluminum) |
| ▼ -NB | Nickel Bronze Traffic Top | -33 | Sediment Bucket (A.R. Finish) |
| -LG | Less Grate | ▽ -35 | Stainless Steel Mesh Bucket Liner |
| -3 | 1/2 Grate | -43 | Internal Dome Strainer (A.R. Finish) |
| -4 | 3/4 Grate | -45 | Less Internal Dome Strainer |
| -7 | Full Grate with 2-1/2" Center Opening | -55 | 1/2" Primer Adapter, 88450 Provided |
| -8 | Stainless Steel Depressed Grate, NB | -C | Clamp Device, 49300, 49300-NB |
| -VP | Secured Grate, Vandal-Proof Screws, NB | | |
| -16 | Grate with 4" Round Funnel | OUTLETS | |
| -17 | Grate with 6" Round Funnel | -X | Inside Caulk Outlet |
| -18 | Grate with 9" x 3-1/2" Oval Funnel | -Z | No-Hub Outlet |
| -20 | Solid Nikaloy Cover, NB | | |
| -24 | Chained Grate, NB | | |
| | | ▽ | Specify -31 or -33 Bucket |

49300-NB SERIES

with -NB Nikaloy Traffic Top

APPLICATION

For use in areas where pedestrian and medium weight wheel loads are anticipated and ultimate sanitation is desired, such as kitchens, hospitals and food processing plants. The 7-1/4" square grate and medium sump accept moderate flow and the dome strainer intercepts debris which could block the drain line. Double drainage flange serves as an anchor in the sub-floor and redirects secondary moisture to the waste line. It may also be used with a clamp device to assure a bond between the drain and the flashing or waterproof membrane.

SPECIFICATION

JOSAM 49300-NB Series square cast iron 6-1/4" deep SUPER-FLO-SEPTOR® Floor Sink with acid-resisting interior, double drainage flange with weepholes, bottom outlet, aluminum internal dome strainer, Nikaloy sanitary sloped rim and Nikaloy light-duty, anti-tilting, SUPER-FLO® Grate.

TYPE NO.	PIPE SIZE	LBS.
49302-NB	2	27
49303-NB	3	27
49304-NB	4	27

SLOT WIDTH 1/2"

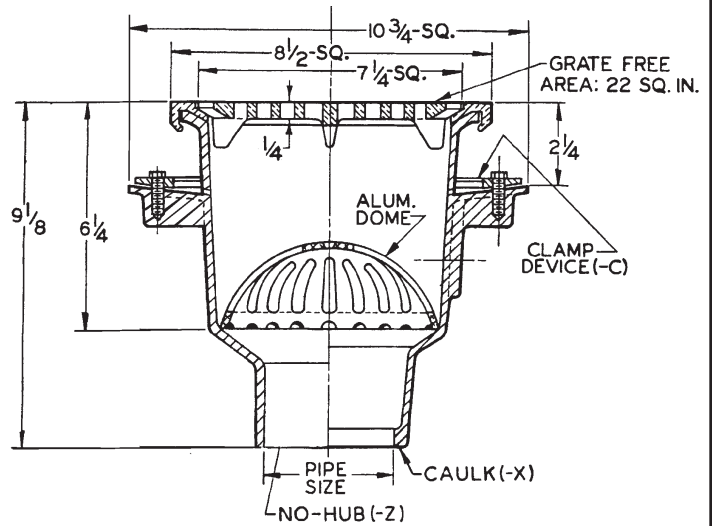

GRATE FREE AREA 22 SQ. IN.

FOR OUTLET TYPE, SPECIFY -X or -Z.

49300-LF-NB SERIES

Less Flange, with -NB Nikaloy Traffic Top

APPLICATION

For use in areas where pedestrian and medium weight wheel loads are anticipated and ultimate sanitation is desired, such as kitchens, hospitals and food processing plants. The 7-1/4" square grate and medium sump accept moderate flow and the dome strainer intercepts debris which could block the drain line.

SPECIFICATION

JOSAM 49300-LF-NB Series square cast iron 6-1/4" deep SUPER-FLO-SEPTOR® Floor Sink with acid-resisting interior, aluminum internal dome strainer, Nikaloy sanitary sloped rim and Nikaloy light-duty, anti-tilting, SUPER-FLO® Grate.

OPTION N/A: -C

TYPE NO.	PIPE SIZE	LBS.
49302-LF-NB	2	24
49303-LF-NB	3	24
49304-LF-NB	4	25

SLOT WIDTH 1/2"

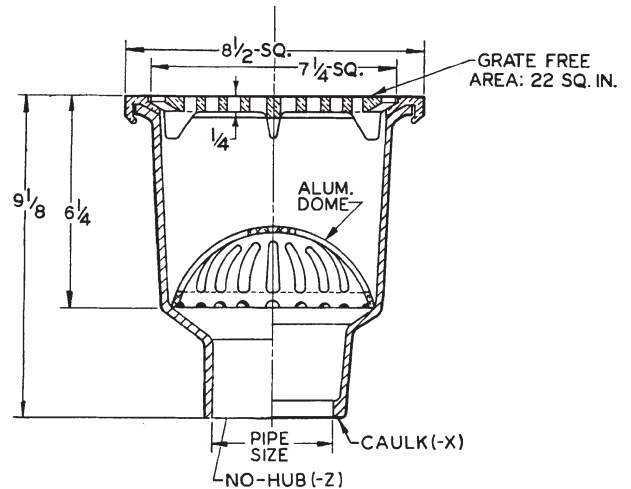

GRATE FREE AREA 22 SQ. IN.

FOR OUTLET TYPE, SPECIFY -X or -Z.