

## 49340A SERIES

## 12" SQUARE TOP, 8" DEEP

### APPLICATION

For use in non-traffic areas where ultimate sanitation is desired, such as kitchens, hospitals and food processing plants. The 10" square grate and medium sump accept moderate to heavy flow and the dome strainer intercepts debris which could block the drain line. Double drainage flange serves as an anchor in the sub-floor and redirects secondary moisture to the waste line. It may also be used with a clamp device to assure a bond between the drain and the flashing or waterproof membrane.

### SPECIFICATION

JOSAM 49340A Series square cast iron 8" deep SUPER-FLO-SEPTOR® Floor Sink with acid-resisting interior, double drainage flange with weepholes, bottom outlet, aluminum internal dome strainer and cast iron, non-traffic, acid-resisting, anti-tilting grate.

## For Options, See Below

OPTIONS N/A: -VP, -8, -20, -24

TYPE NO.	PIPE SIZE	LBS.
49342A	2	50
49343A	3	50
49344A	4	50

SLOT WIDTH 3/8"

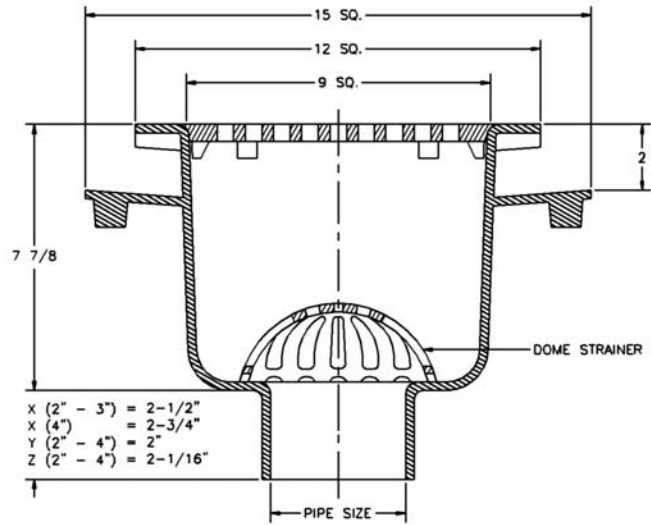

GRATE FREE AREA 26 SQ. IN.

FOR OUTLET TYPE, SPECIFY -X, -Y or -Z.

## 49340A-LF SERIES

## Less Flange

### APPLICATION

For use in non-traffic areas where ultimate sanitation is desired, such as kitchens, hospitals and food processing plants. The 10" square grate and medium sump accept moderate to heavy flow and the dome strainer intercepts debris which could block the drain line.

### SPECIFICATION

JOSAM 49340A-LF Series square cast iron 8" deep SUPER-FLO-SEPTOR® Floor Sink with acid-resisting interior, bottom outlet, aluminum internal dome strainer and cast iron, non-traffic, acid-resisting, anti-tilting grate.

OPTIONS N/A: -VP, -8, -20, -24, -C

TYPE NO.	PIPE SIZE	LBS.
49342A-LF	2	33
49343A-LF	3	33
49344A-LF	4	33

SLOT WIDTH 3/8"

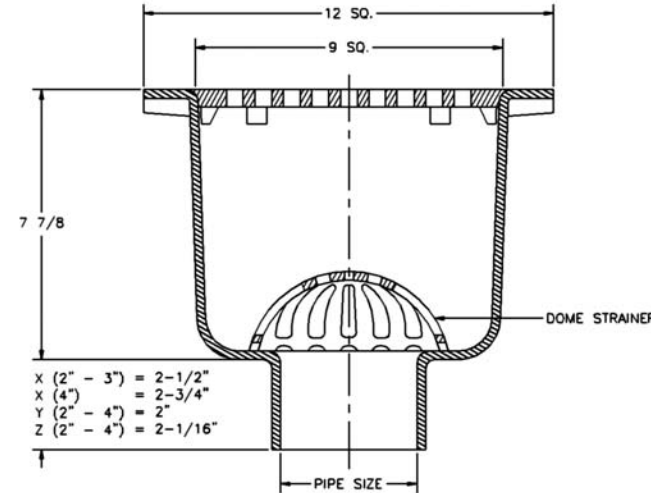

GRATE FREE AREA 26 SQ. IN.

FOR OUTLET TYPE, SPECIFY -X, -Y or -Z.

## OPTIONS

- |       |  |                |                                      |
|-------|--|----------------|--------------------------------------|
| ▼ -LF | Less Flange  | -31            | Sediment Bucket (Aluminum)           |
| ▼ -NB | Nickel Bronze Traffic Top                                    | -33            | Sediment Bucket (A.R. Finish)        |
| -LG   | Less Grate   | ▽ -35          | Stainless Steel Mesh Bucket Liner    |
| -3    | 1/2 Grate  | -43            | Internal Dome Strainer (A.R. Finish) |
| -4    | 3/4 Grate  | -45            | Less Internal Dome Strainer          |
| -5    | Nikaloy Extra Heavy-Duty Grate & Rim (Not SUPER-FLO® Design) | -55            | 1/2" Primer Adapter, 88450 Provided  |
| -7    | Full Grate with 2-1/2" Center Opening                        | -C             | Clamp Device, 49340A, 49340A-NB      |
| -8    | Stainless Steel Depressed Grate, NB                          |                |                                      |
| -VP   | Secured Grate, Vandal-Proof Screws, NB                       |                |                                      |
| -15   | Stainless Steel Rim and Grate                                |                |                                      |
| -16   | Grate with 4" Round Funnel                                   |                |                                      |
| -17   | Grate with 6" Round Funnel                                   |                |                                      |
| -18   | Grate with 9" x 3-1/2" Oval Funnel                           |                |                                      |
| -20   | Solid Nikaloy Cover, NB                                      |                |                                      |
| -24   | Chained Grate, NB  |                |                                      |
|       |  | <b>OUTLETS</b> |                                      |
|       |  | -X             | Inside Caulk Outlet                  |
|       |  | -Y             | Hub Outlet with Gasket               |
|       |  | -Z             | No-Hub Outlet                        |
|       |  |                | ▽ Specify -31 or -33 Bucket          |

## 49340A-NB SERIES

## with -NB Nikaloy Traffic Top

### APPLICATION

For use in areas where pedestrian and medium weight wheel loads are anticipated and ultimate sanitation is desired, such as kitchens, hospitals and food processing plants. The 10" square grate and medium sump accept moderate to heavy flow and the dome strainer intercepts debris which could block the drain line. Double drainage flange serves as an anchor in the sub-floor and redirects secondary moisture to the waste line. It may also be used with a clamp device to assure a bond between the drain and the flashing or waterproof membrane.

### SPECIFICATION

JOSAM 49340A-NB Series square cast iron 8-3/8" deep SUPER-FLO-SEPTOR® Floor Sink with acid-resisting interior, double drainage flange with weepholes, bottom outlet, aluminum internal dome strainer, Nikaloy sanitary sloped rim and Nikaloy, light-duty, anti-tilting, SUPER-FLO® Grate.

SLOT WIDTH 1/2"

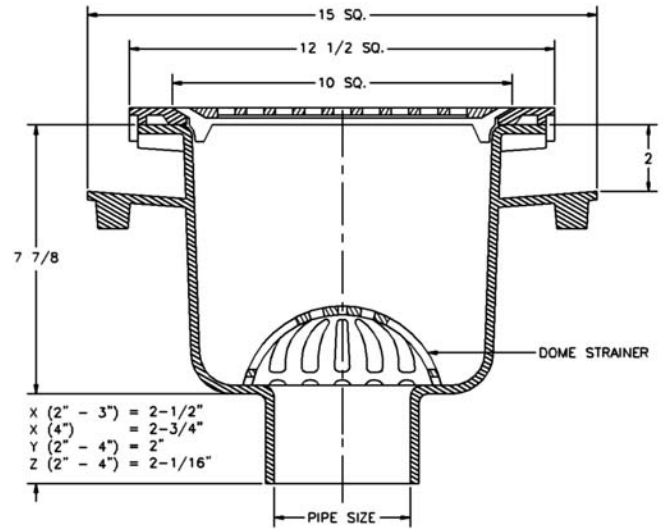

GRATE FREE AREA 35 SQ. IN.

FOR OUTLET TYPE, SPECIFY -X, -Y or -Z.

TYPE NO.	PIPE SIZE	LBS.
49342A-NB	2	50
49343A-NB	3	50
49344A-NB	4	50

## 49340A-LF-NB SERIES

## Less Flange, with -NB Nikaloy Traffic Top

### APPLICATION

For use in areas where pedestrian and medium weight wheel loads are anticipated and ultimate sanitation is desired, such as kitchens, hospitals and food processing plants. The 10" square grate and medium sump accept moderate to heavy flow and the dome strainer intercepts debris which could block the drain line.

### SPECIFICATION

JOSAM 49340A-LF-NB Series square cast iron 8-3/8" deep SUPER-FLO-SEPTOR® Floor Sink with acid-resisting interior, bottom outlet, aluminum internal dome strainer, Nikaloy sanitary sloped rim and Nikaloy, light-duty, anti-tilting, SUPER-FLO® Grate.

OPTION N/A: -C

SLOT WIDTH 1/2"

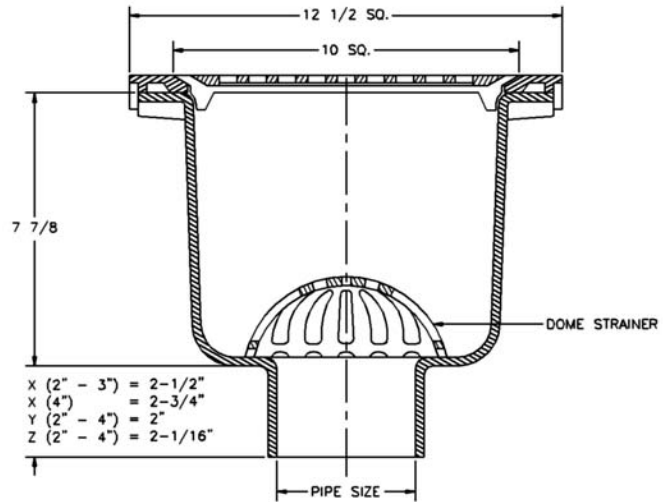

GRATE FREE AREA 35 SQ. IN.

FOR OUTLET TYPE, SPECIFY -X, -Y or -Z.

TYPE NO.	PIPE SIZE	LBS.
49342A-LF-NB	2	33
49343A-LF-NB	3	33
49344A-LF-NB	4	33