

49400 SERIES

16" SQUARE TOP, 6" DEEP

APPLICATION

For use in non-traffic areas where ultimate sanitation is desired, such as kitchens, hospitals, laundries and food processing plants. The 14-1/2" square grate and medium sump accept heavy flow and the dome strainer intercepts debris which could block the drain line. Double drainage flange serves as an anchor in the sub-floor and redirects secondary moisture to the waste line. It may also be used with a clamp device to assure a bond between the drain and the flashing or waterproof membrane.

SPECIFICATION

JOSAM 49400 Series square cast iron 6" deep SUPER-FLO-SEPTOR® Floor Sink with acid-resisting interior, double drainage flange with weepholes, bottom outlet, aluminum internal dome strainer, cast iron, non-traffic, acid-resisting, anti-tilting SUPER-FLO® Grate.

For Options, See Below

OPTION N/A: -VP

TYPE NO.	PIPE SIZE	B DIM.	LBS.
49403	3	9-1/4	99
49404	4	9-1/2	96
49406	6	9-7/8	97

SLOT WIDTH 9/16"

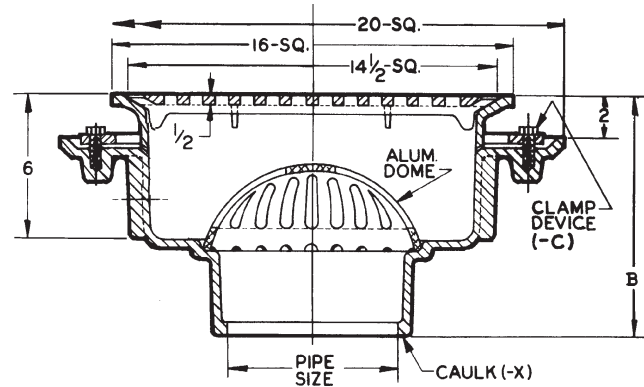

GRATE FREE AREA 94 SQ. IN.

FOR OUTLET TYPE, SPECIFY -X.

49400-LF SERIES

Less Flange

APPLICATION

For use in non-traffic areas where ultimate sanitation is desired, such as kitchens, hospitals, laundries and food processing plants. The 14-1/2" square grate and medium sump accept heavy flow and the dome strainer intercepts debris which could block the drain line.

SPECIFICATION

JOSAM 49400-LF Series square cast iron 6" deep SUPER-FLO-SEPTOR® Floor Sink with acid-resisting interior, bottom outlet, aluminum internal dome strainer, cast iron, non-traffic, acid-resisting, anti-tilting SUPER-FLO® Grate.

OPTIONS N/A: -VP, -C

TYPE NO.	PIPE SIZE	B DIM.	LBS.
49403-LF	3	9-1/4	65
49404-LF	4	9-1/2	67
49406-LF	6	9-7/8	70

SLOT WIDTH 9/16"

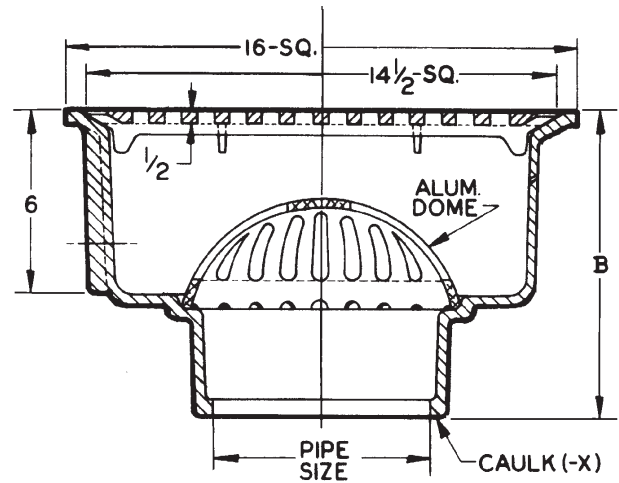

GRATE FREE AREA 94 SQ. IN.

FOR OUTLET TYPE, SPECIFY -X.

OPTIONS

- ▼ -LF Less Flange
- ▼ -NB Nickel Bronze Traffic Top
- LG Less Grate
- 3 1/2 Grate
- 4 3/4 Grate
- 7 Full Grate with 2-1/2" Center Opening
- VP Secured Grate, Vandal-Proof Screws, NB
- 16 Grate with 4" Round Funnel
- 17 Grate with 6" Round Funnel
- 18 Grate with 9" x 3-1/2" Oval Funnel
- 31 Sediment Bucket (Aluminum)
- 33 Sediment Bucket (A.R. Finish)

- ▽ -35 Stainless Steel Mesh Bucket Liner
- 43 Internal Dome Strainer (A.R. Finish)
- 45 Less Internal Dome Strainer
- 55 1/2" Primer Adapter, 88450 Provided for 3", 4"
- 55 1/2" Primer Tap, 6"
- C Clamp Device, 49400, 49400-NB

OUTLET

- X Inside Caulk Outlet

▽ Specify -31 or -33 Bucket

NOTE: For painted or galvanized inside and outside, see 37960 Series.

49400-NB SERIES

with -NB Nikaloy Traffic Top

APPLICATION

For use in areas where pedestrian and medium weight wheel loads are anticipated and ultimate sanitation is desired, such as kitchens, hospitals, laundries and food processing plants. The 14-1/2" square grate and medium sump accept heavy flow and the dome strainer intercepts debris which could block the drain line. Double drainage flange serves as an anchor in the sub-floor and redirects secondary moisture to the waste line. It may also be used with a clamp device to assure a bond between the drain and the flashing or waterproof membrane.

SPECIFICATION

JOSAM 49400-NB Series square cast iron 6-1/4" deep SUPER-FLO-SEPTOR® Floor Sink with acid-resisting interior, double drainage flange with weepholes, bottom outlet, aluminum internal dome strainer, Nikaloy sanitary sloped rim and Nikaloy, light-duty, anti-tilting, SUPER-FLO® Grate.

SLOT WIDTH 1/2"

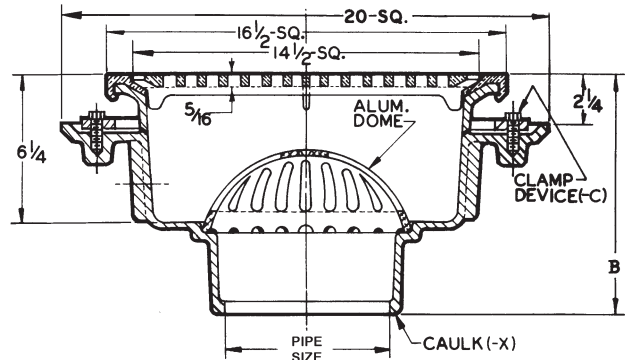

GRATE FREE AREA 93 SQ. IN.

FOR OUTLET TYPE, SPECIFY -X.

TYPE NO.	PIPE SIZE	B DIM.	LBS.
49403-NB	3	9-1/2	110
49404-NB	4	9-3/4	107
49406-NB	6	10-1/8	107

49400-LF-NB SERIES

Less Flange, with -NB Nikaloy Traffic Top

APPLICATION

For use in areas where pedestrian and medium weight wheel loads are anticipated and ultimate sanitation is desired, such as kitchens, hospitals, laundries and food processing plants. The 14-1/2" square grate and medium sump accept heavy flow and the dome strainer intercepts debris which could block the drain line.

SPECIFICATION

JOSAM 49400-LF-NB Series square cast iron 6-1/4" deep SUPER-FLO-SEPTOR® Floor Sink with acid-resisting interior, bottom outlet, aluminum internal dome strainer, Nikaloy sanitary sloped rim and Nikaloy, light-duty, anti-tilting, SUPER-FLO® Grate.

OPTION N/A: -C

SLOT WIDTH 1/2"

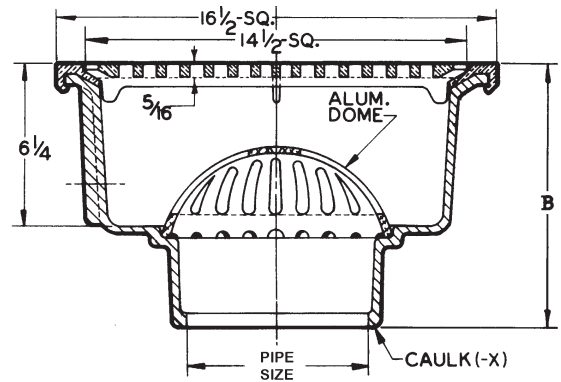

GRATE FREE AREA 93 SQ. IN.

FOR OUTLET TYPE, SPECIFY -X.

TYPE NO.	PIPE SIZE	B DIM.	LBS.
49403-LF-NB	3	9-1/2	76
49404-LF-NB	4	9-3/4	77
49406-LF-NB	6	10-1/8	80