

49500 SERIES

SUPER-FLO® 8" ROUND TOP, 3" DEEP

APPLICATION

For use in non-traffic areas where ultimate sanitation is desired, such as kitchens, hospitals and food processing plants. The 7-1/4" diameter grate and shallow sump accept light flow and the dome strainer intercepts debris which could block the drain line. Double drainage flange serves as an anchor in the sub-floor and redirects secondary moisture to the waste line. It may also be used with a clamp device to assure a bond between the drain and the flashing or waterproof membrane.

SPECIFICATION

JOSAM 49500 Series round cast iron 3-5/16" deep SUPER-FLO-SEPTOR® Floor Sink with acid-resisting interior, double drainage flange with weepholes, bottom outlet, aluminum internal dome strainer and cast iron, non-traffic, acid-resisting, anti-tilting, SUPER-FLO® Grate.

For Options, See Below

OPTIONS N/A: -VP, -8

TYPE NO.	PIPE SIZE	LBS.
49502	2	15
49503	3	16
49504	4	17

SLOT WIDTH 7/16"

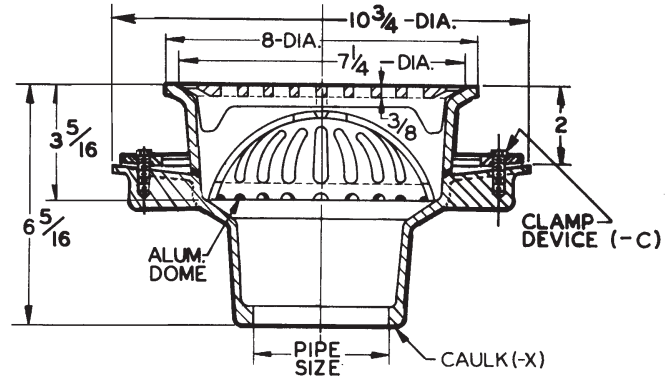

GRATE FREE AREA 15.5 SQ. IN.

FOR OUTLET TYPE, SPECIFY -X.

49500-LF SERIES

Less Flange

APPLICATION

For use in non-traffic areas where ultimate sanitation is desired, such as kitchens, hospitals and food processing plants. The 7-1/4" diameter grate and shallow sump accept light flow and the dome strainer intercepts debris which could block the drain line.

SPECIFICATION

JOSAM 49500-LF Series round cast iron 3-5/16" deep SUPER-FLO-SEPTOR® Floor Sink with acid-resisting interior, bottom outlet, aluminum internal dome strainer and cast iron, non-traffic, acid-resisting, anti-tilting, SUPER-FLO® Grate.

OPTIONS N/A: -VP, -C, -8

TYPE NO.	PIPE SIZE	LBS.
49502-LF	2	14
49503-LF	3	15
49504-LF	4	15

SLOT WIDTH 7/16"

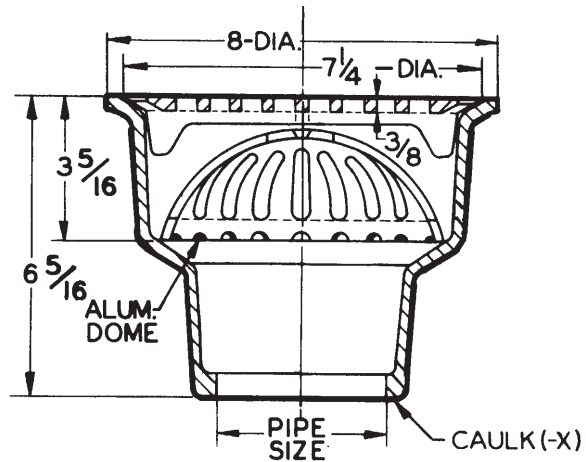

GRATE FREE AREA 15.5 SQ. IN.

FOR OUTLET TYPE, SPECIFY -X.

OPTIONS

- ▼ -LF Less Flange
- ▼ -NB Nickel Bronze Traffic Top
- LG Less Grate
- 3 1/2 Grate
- 4 3/4 Grate
- 7 Full Grate with 2-1/2" Center Opening
- 8 Depressed Grate (Aluminum), NB
- VP Secured Grate, Vandal-Proof Screws, NB
- 16 Grate with 4" Round Funnel
- 17 Grate with 6" Round Funnel
- 18 Grate with 9" x 3-1/2" Oval Funnel
- 31 Sediment Bucket (Aluminum)
- 33 Sediment Bucket (A.R. Finish)

- ▽ -35 Stainless Steel Mesh Bucket Liner
- 43 Internal Dome Strainer (A.R. Finish)
- 45 Less Internal Dome Strainer
- 51 Galvanized Cast Iron Inside and Outside
- 52 Painted Inside and Outside
- 55 1/2" Primer Adaptor, 88450 Provided
- C Clamp Device, 49500, 49500-NB

OUTLET

- X Inside Caulk Outlet

▽ Specify -31 or -33 Bucket

49500-NB SERIES

with -NB Nikaloy Traffic Top

APPLICATION

For use in areas where pedestrian and medium weight wheel loads are anticipated and ultimate sanitation is desired, such as kitchens, hospitals and food processing plants. The 7-1/4" diameter grate and shallow sump accept light flow and the dome strainer intercepts debris which could block the drain line. Double drainage flange serves as an anchor in the sub-floor and redirects secondary moisture to the waste line. It may also be used with a clamp device to assure a bond between the drain and the flashing or waterproof membrane.

SPECIFICATION

JOSAM 49500-NB Series round cast iron 3-9/16" deep SUPER-FLO-SEPTOR® Floor Sink with acid-resisting interior, double drainage flange with weepholes, bottom outlet, aluminum internal dome strainer, Nikaloy sanitary sloped rim and Nikaloy, light-duty, anti-tilting, SUPER-FLO® Grate.

SLOT WIDTH 3/8"

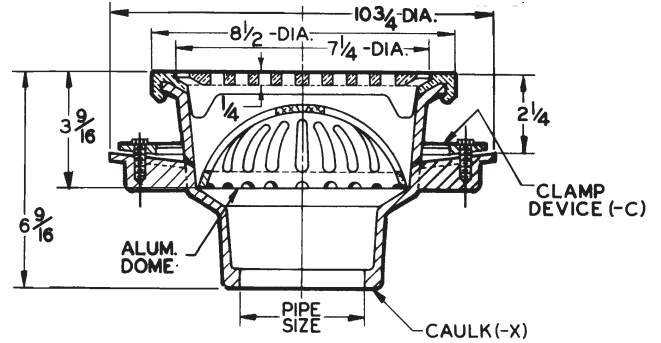

TYPE NO.	PIPE SIZE	LBS.
49502-NB	2	19
49503-NB	3	19
49504-NB	4	20

GRATE FREE AREA 17 SQ. IN.

FOR OUTLET TYPE, SPECIFY -X.

49500-LF-NB SERIES

Less Flange, with -NB Nikaloy Traffic Top

APPLICATION

For use in areas where pedestrian and medium weight wheel loads are anticipated and ultimate sanitation is desired, such as kitchens, hospitals and food processing plants. The 7-1/4" diameter grate and shallow sump accept light flow and the dome strainer intercepts debris which could block the drain line.

SPECIFICATION

JOSAM 49500-LF-NB Series round cast iron 3-9/16" deep SUPER-FLO-SEPTOR® Floor Sink with acid-resisting interior, bottom outlet, aluminum internal dome strainer, Nikaloy sanitary sloped rim and Nikaloy, light-duty, anti-tilting, SUPER-FLO® Grate.

OPTION N/A: -C

SLOT WIDTH 3/8"

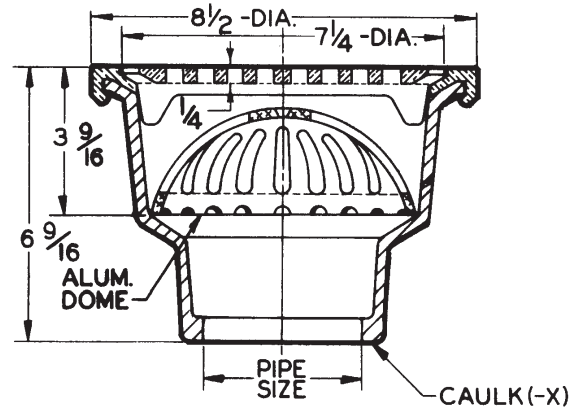

TYPE NO.	PIPE SIZE	LBS.
49502-LF-NB	2	17
49503-LF-NB	3	18
49504-LF-NB	4	18

GRATE FREE AREA 17 SQ. IN.

FOR OUTLET TYPE, SPECIFY -X.