

49580A SERIES

SUPER-FLO® 12" ROUND TOP, 8" DEEP

APPLICATION

For use in areas where pedestrian and medium weight wheel loads are anticipated and ultimate sanitation is desired, such as kitchens, hospitals and food processing plants. The 10-1/2" diameter grate and deep sump accept heavy flow and the dome strainer intercepts debris which could block the drain line. Double drainage flange serves as an anchor in the sub-floor and redirects secondary moisture to the waste line. It may also be used with a clamp device to assure a bond between the drain and the flashing or waterproof membrane.

SPECIFICATION

JOSAM 49580A Series round cast iron 8" deep SUPER-FLO-SEPTOR® Floor Sink with acid-resisting interior, double drainage flange with weepholes, bottom outlet, aluminum internal dome strainer, cast iron, non-traffic, acid-resisting, anti-tilting, SUPER-FLO® Grate.

For Options, See Below

OPTIONS N/A: -VP, -8

TYPE NO.	PIPE SIZE	LBS.
49582A	2	45
49583A	3	46
49584A	4	47

SLOT WIDTH 3/4"

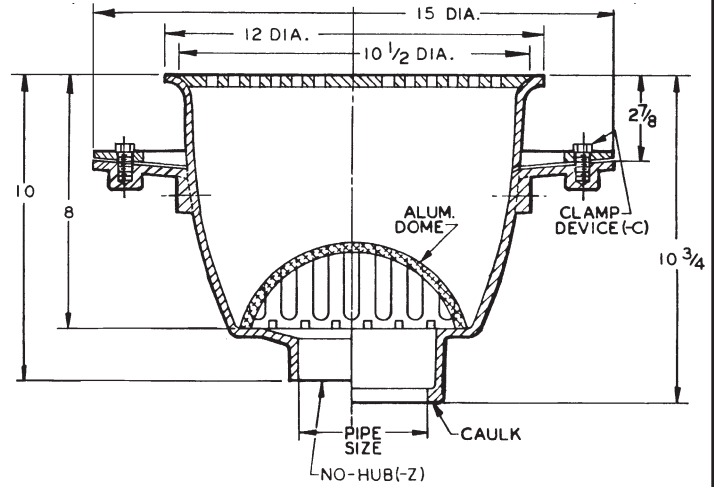

GRATE FREE AREA 19.7 SQ. IN.

FOR OUTLET TYPE, SPECIFY -X or -Z.

49580A-LF SERIES

Less Flange

APPLICATION

For use in areas where pedestrian and medium weight wheel loads are anticipated and ultimate sanitation is desired, such as kitchens, hospitals and food processing plants. The 10-1/2" diameter grate and deep sump accept heavy flow and the dome strainer intercepts debris which could block the drain line.

SPECIFICATION

JOSAM 49580A-LF Series round cast iron 8" deep SUPER-FLO-SEPTOR® Floor Sink with acid-resisting interior, bottom outlet, aluminum internal dome strainer, cast iron, non-traffic, acid-resisting, anti-tilting, SUPER-FLO® Grate.

OPTIONS N/A: -VP, -C, -8

TYPE NO.	PIPE SIZE	LBS.
49582A-LF	2	37
49583A-LF	3	38
49584A-LF	4	39

SLOT WIDTH 3/4"

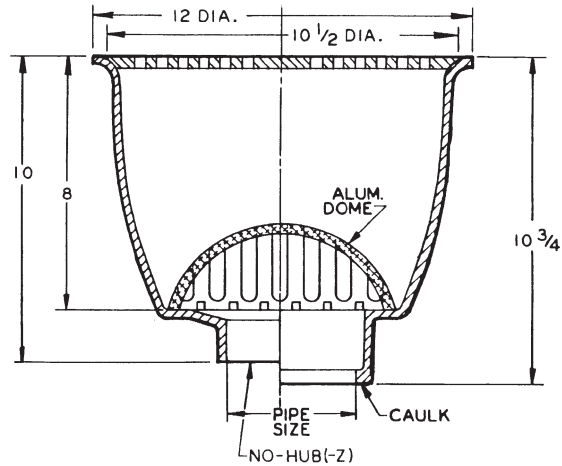

GRATE FREE AREA 19.7 SQ. IN.

FOR OUTLET TYPE, SPECIFY -X or -Z.

OPTIONS

- | | | | |
|-------|--|-------|---|
| ▼ -LF | Less Flange | ▽ -35 | Stainless Steel Mesh Bucket Liner |
| ▼ -NB | Nickel Bronze Traffic To | -43 | Internal Dome Strainer (A.R. Finish) |
| -LG | Less Grate | -45 | Less Internal Dome Strainer |
| -3 | 1/2 Grate | -51 | Galvanized Cast Iron Inside and Outside |
| -4 | 3/4 Grate | -52 | Painted Inside and Outside |
| -7 | Full Grate with 2-1/2" Center Opening | -55 | 1/2" Primer Adapter, 88450 Provided |
| -8 | Depressed Grate, (Aluminum), NB | -C | Clamp Device, 49580A, 49580A-NB |
| -VP | Secured Grate, Vandal-Proof Screws, NB | | |
| -16 | Grate with 4" Round Funnel | | |
| -17 | Grate with 6" Round Funnel | | |
| -18 | Grate with 9" x 3-1/2" Oval Funnel | | |
| -31 | Sediment Bucket (Aluminum) | | |
| -33 | Sediment Bucket (A.R. Finish) | | |

OUTLETS

- X Inside Caulk Outlet
- Z No-Hub Outlet

▽ Specify -31 or -33 Bucket

49580A-NB SERIES

with -NB Nikaloy Traffic Top

APPLICATION

For use in areas where pedestrian and medium weight wheel loads are anticipated and ultimate sanitation is desired, such as kitchens, hospitals and food processing plants. The 11-1/8" diameter grate and deep sump accept heavy flow and the dome strainer intercepts debris which could block the drain line. Double drainage flange serves as an anchor in the sub-floor and redirects secondary moisture to the waste line. It may also be used with a clamp device to assure a bond between the drain and the flashing or waterproof membrane.

SPECIFICATION

JOSAM 49580A-NB Series round cast iron 8-1/4" deep SUPER-FLO-SEPTOR® Floor Sink with acid-resisting interior, double drainage flange with weepholes, bottom outlet, aluminum internal dome strainer, Nikaloy sanitary sloped rim and Nikaloy, light-duty, anti-tilting, SUPER-FLO® Grate.

SLOT WIDTH 1/2"

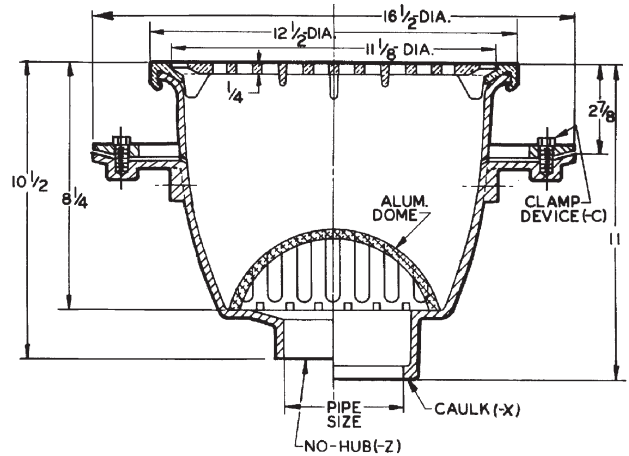

TYPE NO.	PIPE SIZE	LBS.
49582A-NB	2	50
49583A-NB	3	51
49584A-NB	4	52

GRATE FREE AREA 40 SQ. IN.

FOR OUTLET TYPE, SPECIFY -X or -Z.

49580A-LF-NB SERIES

Less Flange, with -NB Nikaloy Traffic Top

APPLICATION

For use in areas where pedestrian and medium weight wheel loads are anticipated and ultimate sanitation is desired, such as kitchens, hospitals and food processing plants. The 11-1/8" diameter grate and deep sump accept heavy flow and the dome strainer intercepts debris which could block the drain line.

SPECIFICATION

JOSAM 49580A-LF-NB Series round cast iron 8-1/4" deep SUPER-FLO-SEPTOR® Floor Sink with acid-resisting interior, bottom outlet, aluminum internal dome strainer, Nikaloy sanitary sloped rim and Nikaloy, light-duty, anti-tilting, SUPER-FLO® Grate.

OPTION N/A: -C

SLOT WIDTH 1/2"

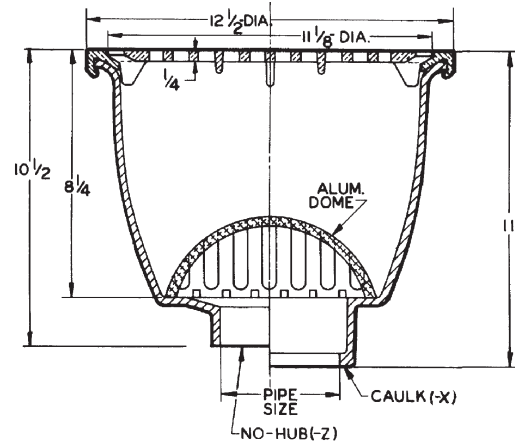

TYPE NO.	PIPE SIZE	LBS.
49582A-LF-NB	2	43
49583A-LF-NB	3	43
49584A-LF-NB	4	44

GRATE FREE AREA 40 SQ. IN.

FOR OUTLET TYPE, SPECIFY -X or -Z.