

49700 SERIES

4" X 8" RECTANGULAR TOP, 4' DEEP

APPLICATION

For use in non-traffic areas where space is limited such as under counters or against walls and ultimate sanitation is desired, such as kitchens, hospitals and food prep stations. The 3-3/8" x 7-3/8" rectangular grate and shallow sump accept light flow and the secondary strainer intercepts debris which could block the drain line. Double drainage flange serves as an anchor in the sub-floor and redirects secondary moisture to the waste line. It may also be used with a clamp device to assure a bond between the drain and the flashing or waterproof membrane.

SPECIFICATION

JOSAM 49700 Series rectangular cast iron 3-1/2" deep SUPER-FLO-SEPTOR® Floor Sink with acid-resisting interior, double drainage flange with weepholes, bottom outlet, aluminum internal dome strainer and cast iron, non-traffic, acid-resisting grate.

For Options, See Below

OPTIONS N/A: -VP, -8

TYPE NO.	PIPE SIZE	LBS.
49702	2	24
49703	3	24

SLOT WIDTH 1/4"

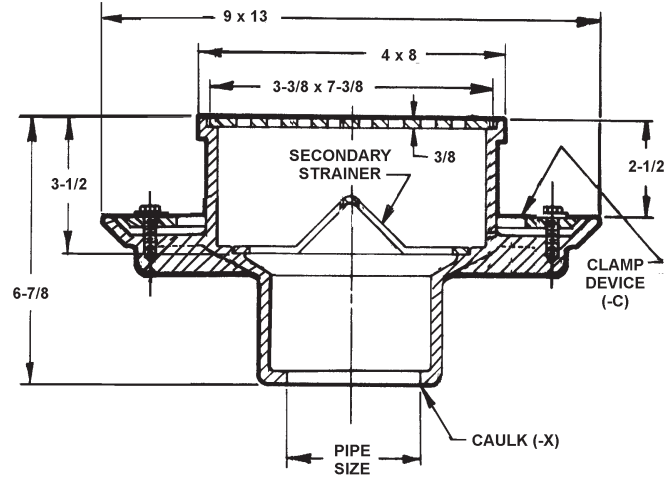

GRATE FREE AREA 7 SQ. IN.

FOR OUTLET TYPE, SPECIFY -X.

49700-LF SERIES

Less Flange

APPLICATION

For use in non-traffic areas where space is limited such as under counters or against walls and ultimate sanitation is desired, such as kitchens, hospitals and food prep stations. The 3-3/8" x 7-3/8" rectangular grate and shallow sump accept light flow and the secondary strainer intercepts debris which could block the drain line.

SPECIFICATION

JOSAM 49700-LF Series rectangular cast iron 3-1/2" deep SUPER-FLO-SEPTOR® Floor Sink with acid-resisting interior, bottom outlet, aluminum internal dome strainer and cast iron, non-traffic, acid-resisting grate.

OPTIONS N/A: -VP, -C, -8

TYPE NO.	PIPE SIZE	LBS.
49702-LF	2	13
49703-LF	3	15

SLOT WIDTH 1/4"

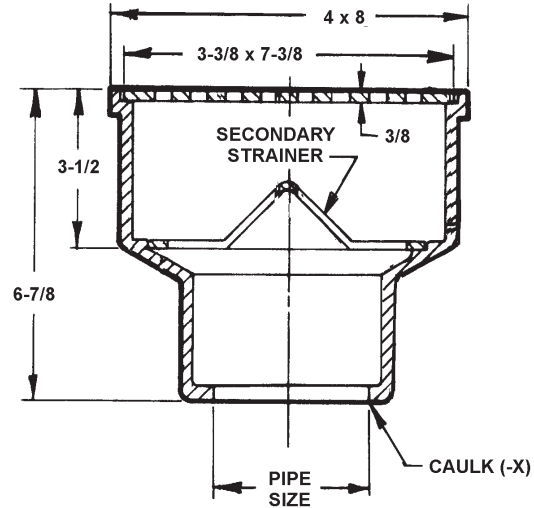

GRATE FREE AREA 7 SQ. IN.

FOR OUTLET TYPE, SPECIFY -X.

OPTIONS

- ▼ -LF Less Flange
 - ▼ -NB Nickel Bronze Traffic Top
 - LG Less Grate
 - 3 1/2 Grate
 - 4 3/4 Grate
 - 7 Full Grate with 2-1/2" Center Opening
 - 8 Depressed Grate, (Aluminum), NB
 - VP Secured Grate, Vandal-Proof Screws, NB
 - 16 Grate with 4" Round Funnel
 - 30 Stainless Steel Sediment Bucket
 - 43 Internal Dome Strainer (A.R. Finish)
 - 45 Less Internal Dome Strainer
 - 51 Galvanized Cast Iron Inside and Outside
 - 52 Painted Inside and Outside
 - 55 1/2" Primer Adapter, 88450 Provided
 - C Clamp Device, 49700, 49700-NB
- OUTLETS**
- X Inside Caulk Outlet

49700-NB SERIES

with -NB Nikaloy Traffic Top

APPLICATION

For use in areas where pedestrian and medium weight wheel loads are anticipated or space is limited such as under counters or against walls and ultimate sanitation is desired, such as kitchens, hospitals and food prep stations. The 3-3/8" x 7-3/8" rectangular grate and shallow sump accept light flow and the secondary strainer intercepts debris which could block the drain line. Double drainage flange serves as an anchor in the sub-floor and redirects secondary moisture to the waste line. It may also be used with a clamp device to assure a bond between the drain and the flashing or waterproof membrane.

SPECIFICATION

JOSAM 49700-NB Series rectangular cast iron 4" deep SUPER-FLO-SEPTOR® Floor Sink with acid-resisting interior, double drainage flange with weepholes, bottom outlet, aluminum internal dome strainer, Nikaloy rim and light-duty, anti-tilting, Nikaloy grate.

TYPE NO.	PIPE SIZE	LBS.
49702-NB	2	26
49703-NB	3	26

SLOT WIDTH 1/4"

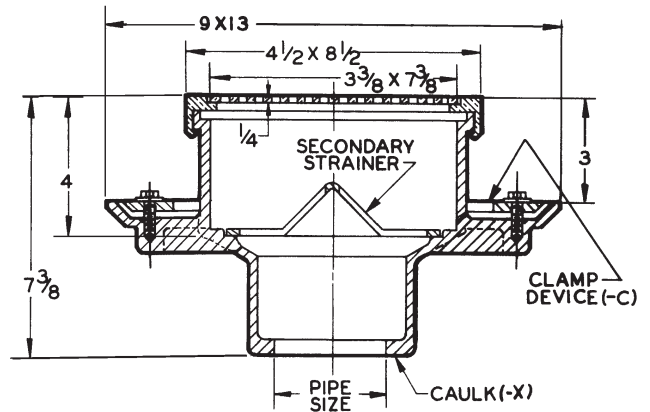

GRATE FREE AREA 10 SQ. IN.

FOR OUTLET TYPE, SPECIFY -X.

49700-LF-NB SERIES

Less Flange, with -NB Nikaloy Traffic Top

APPLICATION

For use in areas where pedestrian and medium weight wheel loads are anticipated or space is limited such as under counters or against walls and ultimate sanitation is desired, such as kitchens, hospitals and food prep stations. The 3-3/8" x 7-3/8" rectangular grate and shallow sump accept light flow and the secondary strainer intercepts debris which could block the drain line.

SPECIFICATION

JOSAM 49700-LF-NB Series rectangular cast iron 4" deep SUPER-FLO-SEPTOR® Floor Sink with acid-resisting interior, bottom outlet, aluminum internal dome strainer, Nikaloy rim and light-duty, anti-tilting, Nikaloy grate.

OPTION N/A: -C

TYPE NO.	PIPE SIZE	LBS.
49702-LF-NB	2	15
49703-LF-NB	3	18

SLOT WIDTH 1/4"

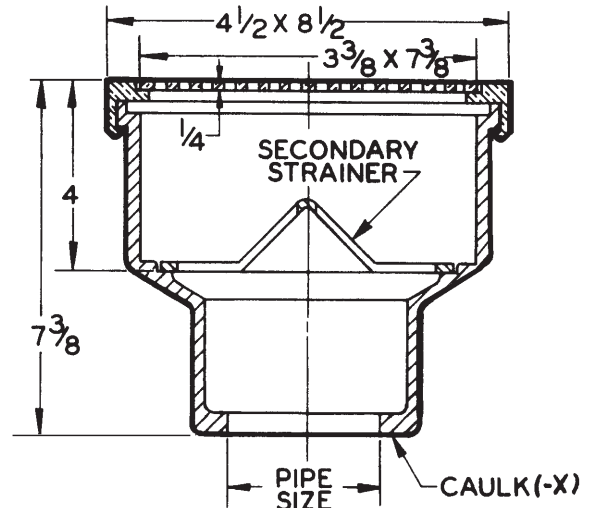

GRATE FREE AREA 10 SQ. IN.

FOR OUTLET TYPE, SPECIFY -X.