

60100H SERIES MANUAL CLEANING, ON-FLOOR TYPE

APPLICATION

For use in restaurant and institutional kitchens and all types of food handling and processing areas where waste water contains fats, oil and grease (FOG). Adequate space and head room for removal of cover must be available for manual cleaning.

SPECIFICATION

JOSAM 60100H Series epoxy coated fabricated steel Grease Interceptor, no-hub connections, internal trap, removable diffuser baffle, gasketed non-skid cover, flow control fitting and PDI Seal of Approval. Conforms to Plumbing & Drainage Institute Standard PDI-G101.



Conforms to Plumbing and Drainage Institute Standard PDI-G101.

Available Options

- 40 Cover Recess for Floor Finish
- 61 Flange and Clamp Device
- * -ISI Integrated Solids Interceptor
- ▼ -EXT Extension, 6" Standard. (Specify Extension Height)
- ▼ -RT Recessed Type
- ▼ -ET Enclosed Type
- HD Heavy-Duty Cover
- SS Stainless Steel Interceptor
- ▼ -GRD* Grease Removal Device, 60104H-60110H
- † -GRDP Grease Recovery Device with Probe
- SAP Sensing and Alarm Probe

* -ISI and -GRD cannot be furnished together. † 60100H-GRDP meets ANSI A112.14.4

TYPE NO.	FLOW RATE GPM	GREASE CAP LBS.	PIPE SIZE	ROUGH-IN CENTERS		LGTH. E	WIDTH F	HGT. G	LBS.
				C	D				
60102H	7	14	2	8-1/4	3-3/8	14-7/8	13	11-5/8	35
60103H	10	20	2	8-1/2	3-3/8	16-5/8	14-1/2	11-7/8	45
60104H	15	30	2	9-1/2	3-3/8	20-3/8	17	12-7/8	60
60105H	20	40	3	12	4-7/8	20-7/8	19	16-7/8	70
60106H	25	50	3	13	4-7/8	23-3/8	21-1/2	17-7/8	90
60107H	35	70	3	14-1/2	4-7/8	26-1/8	23	19-3/8	110
60108H	50	100	3	16-1/2	4-7/8	27-7/8	25-1/2	21-3/8	135
60109H	75	150	3	21	6	41	31	27	220
60110H	100	200	4	23	8	47	35	31	325

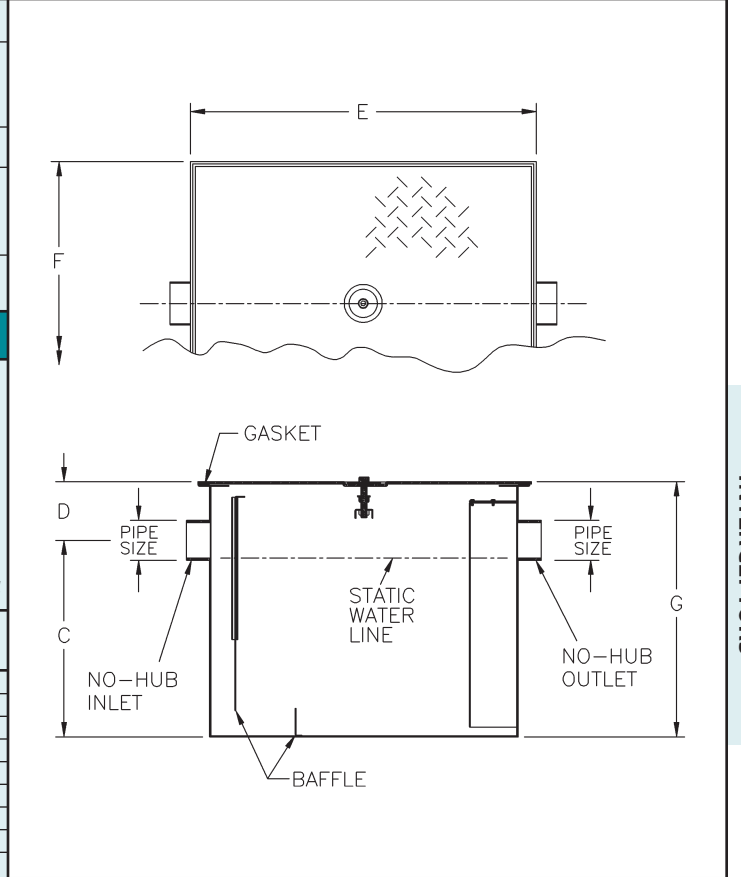

60100H-GRD SERIES with Grease Removal Device

APPLICATION

For use in restaurant and institutional kitchens and all types of food handling and processing areas where waste water contains fats, oil and grease (FOG). The Grease Removal Device (GRD), with programmable timer, controls the internal pump to remove grease on schedule.

SPECIFICATION

JOSAM 60100H-GRD Series epoxy coated fabricated steel Grease Interceptor, no-hub connections, internal trap, removable baffle, gasketed non-skid cover, flow control fitting and PDI Seal of Approval. Programmable timer controls internal pump for removal of grease at predetermined intervals.

OPTION N/A:
-ISI

TYPE NO.	FLOW RATE GPM	GREASE CAP LBS.	PIPE SIZE	ROUGH-IN CENTERS		LGTH. E	WIDTH F	HGT. G	LBS.
				C	D				
60104H-GRD	15	30	2	9-1/2	3-3/8	20-3/8	17	12-7/8	90
60105H-GRD	20	40	3	12	4-7/8	20-7/8	19	16-7/8	100
60106H-GRD	25	50	3	13	4-7/8	23-3/8	21-1/2	17-7/8	120
60107H-GRD	35	70	3	14-1/2	4-7/8	26-1/8	23	19-3/8	140
60108H-GRD	50	100	3	16-1/2	4-7/8	27-7/8	25-1/2	21-3/8	165
60109H-GRD	75	150	3	21	6	41	31	27	250
60110H-GRD	100	200	4	23	8	47	35	31	355

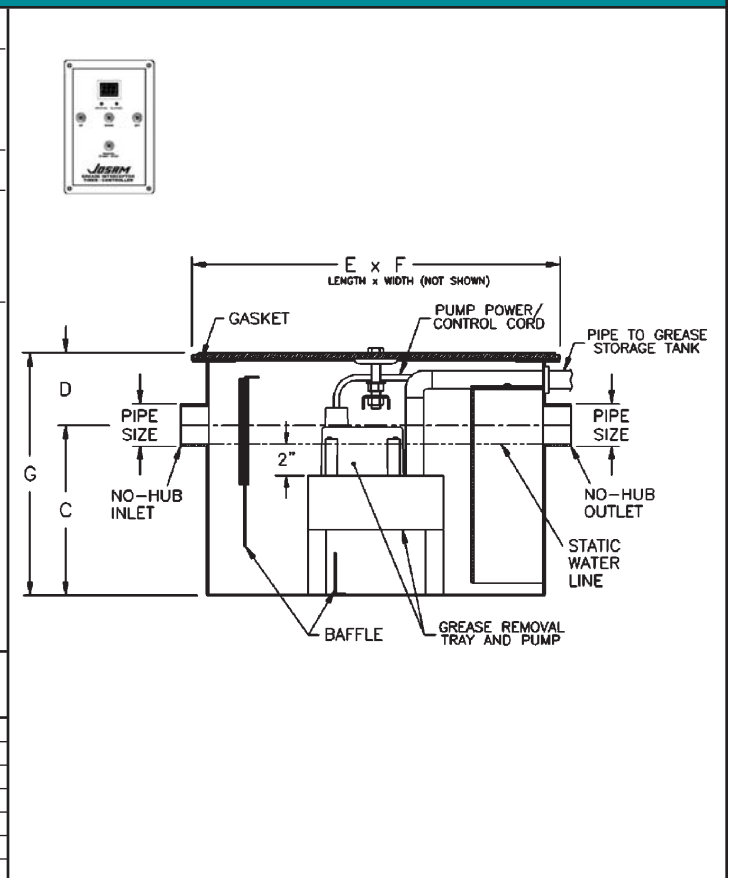

INTERCEPTORS

60100H-EXT SERIES

with Extension

APPLICATION

For use in restaurant and institutional kitchens and all types of food handling and processing areas where waste water contains fats, oil and grease (FOG). Extended top with fixed extension for installations requiring additional roughing depth from the cover of the interceptor to the inlet and outlet.

SPECIFICATION

JOSAM 60100H-EXT Series epoxy coated fabricated steel Grease Interceptor, deep roughing, integral extension, flush-with-floor type, no-hub connections, internal trap, removable diffuser baffle, gasketed non-skid cover, flow control fitting and PDI Seal of Approval.



Conforms to Plumbing and Drainage Institute Standard PDI-G101.

TYPE NO.	FLOW RATE GPM	GREASE CAP LBS.	PIPE SIZE	ROUGH-IN CENTERS		LGTH. E	WIDTH F	HGT. G	LBS.
				C	D				
60102H-EXT	7	14	2	8-1/4	9-3/8	14-7/8	13	17-5/8	35
60103H-EXT	10	20	2	8-1/2	9-3/8	16-5/8	14-1/2	17-7/8	45
60104H-EXT	15	30	2	9-1/2	9-3/8	20-3/8	17	18-7/8	60
60105H-EXT	20	40	3	12	10-7/8	20-7/8	19	22-7/8	70
60106H-EXT	25	50	3	13	10-7/8	23-3/8	21-1/2	23-7/8	90
60107H-EXT	35	70	3	14-1/2	10-7/8	26-1/8	23	25-3/8	110
60108H-EXT	50	100	3	16-1/2	10-7/8	27-7/8	25-1/2	27-3/8	135
60109H-EXT	75	150	3	21	12	41	31	33	220
60110H-EXT	100	200	4	23	14	47	35	37	325

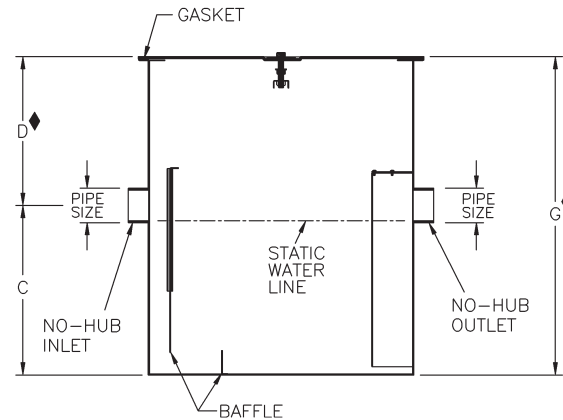
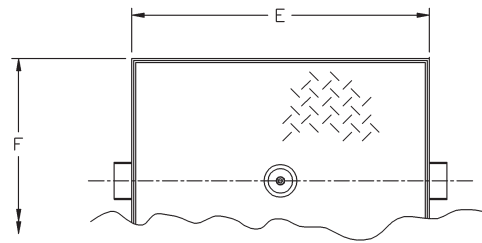

◆ DIMENSIONS BASED ON STD. 6" EXTENSION.

60100H-ET SERIES

Enclosed Type

APPLICATION

For use in restaurant and institutional kitchens and all types of food handling and processing areas where waste water contains fats, oil and grease (FOG). Steel enclosure cabinet for installation flush with the floor, completely enclosed, where adjustment of interceptor elevation is necessary for connection to a deep drain line.

SPECIFICATION

JOSAM 60100H-ET Series epoxy coated fabricated steel Grease Interceptor, deep roughing, flush-with-floor type, no-hub connections, internal trap, removable diffuser baffle, gasketed non-skid cover, flow control fitting, PDI Seal of Approval and steel enclosure cabinet with non-skid cover and adjustable interceptor carrier brackets.



Conforms to Plumbing and Drainage Institute Standard PDI-G101.

TYPE NO.	FLOW RATE GPM	GREASE CAP LBS.	PIPE SIZE	WIDTH B	ROUGH-IN CENTERS		INTER. LGTH. E	ENCL. LGTH. F	HGT. G	LBS.
					C	D				
60102H-ET	7	14	2	15	8-1/4	8-3/4	14-7/8	23	25-3/4	143
60103H-ET	10	20	2	16-1/2	8-1/2	8-3/4	16-5/8	24-3/4	26	185
60104H-ET	15	30	2	19	9-1/2	8-3/4	20-3/8	28-1/2	27	232
60105H-ET	20	40	3	21	12	10-1/4	20-7/8	29	31	274
60106H-ET	25	50	3	23-1/2	13	10-1/4	23-3/8	31-1/2	32	356
60107H-ET	35	70	3	25	14-1/2	10-1/4	26-1/8	34-1/4	33-1/2	378
60108H-ET	50	100	3	27-1/2	16-1/2	10-1/4	27-7/8	36	35-1/2	435
60109H-ET	75	150	3	33	21	11-3/8	41	49-1/8	41-1/8	780
60110H-ET	100	200	4	37	23	13-3/8	47	55-1/8	45-1/8	1075

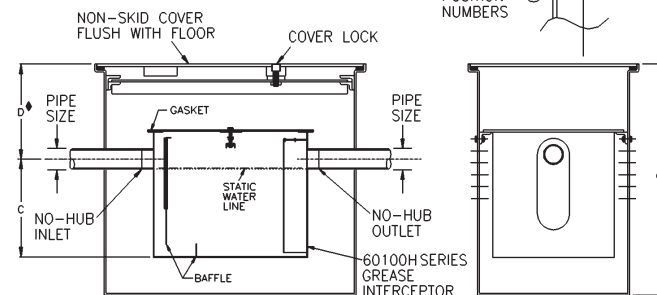
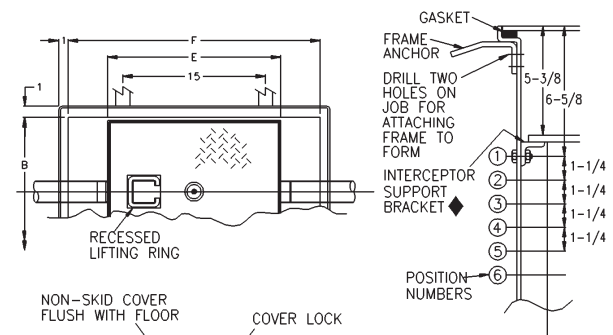

◆ BASED ON INTERCEPTOR IN POSITION #1, ADD 1-1/4" WHEN LOWERING INTERCEPTOR TO SUCCEEDING POSITIONS.

INTERCEPTOR SUPPORT BRACKET ADJUSTABLE FOR VARYING DEPTHS OF FLOOR CONSTRUCTION.

INTERCEPTORS

60100H-RT SERIES

Recessed Type

APPLICATION

For use in restaurant and institutional kitchens and all types of food handling and processing areas where waste water contains fats, oil and grease (FOG). Steel frame and cover for installation flush with the floor where adjustment of interceptor elevation is necessary for connection to a deep drain line.

SPECIFICATION

JOSAM 60100H-RT Series epoxy coated fabricated steel Grease Interceptor, deep roughing, recessed, flush-with-floor type, no-hub connections, internal trap, removable diffuser baffle, gasketed non-skid cover, flow control fitting, PDI Seal of Approval and steel frame with non-skid cover and adjustable interceptor carrier brackets.



Conforms to Plumbing and Drainage Institute Standard PDI-G101.

TYPE NO.	FLOW RATE GPM	GREASE CAP LBS.	PIPE SIZE	WIDTH B	ROUGH-IN CENTERS		INTER. LGTH. E	ENCL. LGTH. F	HGT. G	LBS.
					C	D◆				
60102H-RT	7	14	2	15	8-1/4	8-3/4	14-7/8	19	14-3/4	102
60103H-RT	10	20	2	16-3/8	8-1/2	8-3/4	16-5/8	21	14-3/4	120
60104H-RT	15	30	2	18-1/2	9-1/2	8-3/4	20-3/8	24	14-3/4	151
60105H-RT	20	40	3	20-1/4	12	10-1/4	20-7/8	26	14-3/4	175
60106H-RT	25	50	3	22-1/2	13	10-1/4	23-3/8	29	14-7/8	197
60107H-RT	35	70	3	24	14-1/2	10-1/4	26-1/8	31	14-7/8	225
60108H-RT	50	100	3	26-5/8	16-1/2	10-1/4	27-7/8	33	14-7/8	258
60109H-RT	75	150	3	33	21	11-3/8	41	49-1/8	15-3/4	455
60110H-RT	100	200	4	37	23	13-3/8	47	55-1/8	15-3/4	625

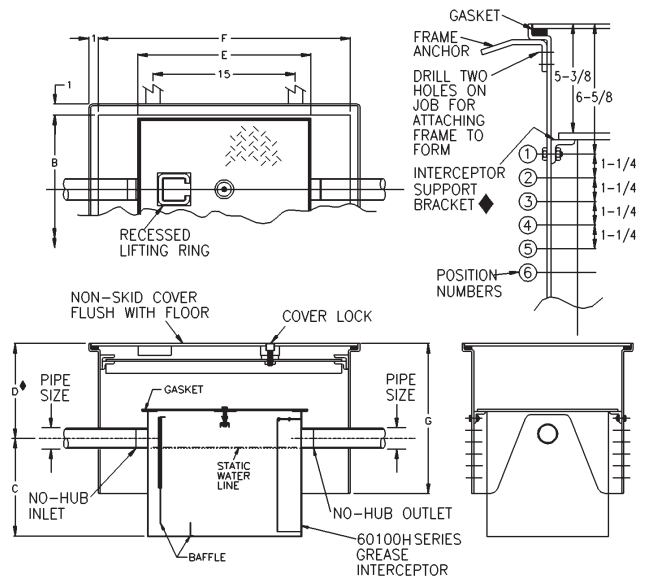

◆ BASED ON INTERCEPTOR IN POSITION #1, ADD 1-1/4" WHEN LOWERING INTERCEPTOR TO SUCCEEDING POSITIONS.
INTERCEPTOR SUPPORT BRACKET ADJUSTABLE FOR VARYING DEPTHS OF FLOOR CONSTRUCTION.