

17390 SERIES

WALL-MOUNT, Exposed Arms

APPLICATION

For use with lavatories designed for heavy-duty exposed arms where wall construction will support the fixture and carrier assembly.

SPECIFICATION

JOSAM 17390 Series wall-mounted, single Lavatory Carrier with exposed acid-resisting white coated arms, leveling and securing screws, adjustable wall plate and chrome-plated trim.

Available Options

- ▼ -BP with Back Plates
- VP Vandal-Proof Trim
- 10 Hardware for Walls Over 4-1/2", Specify Wall Thickness

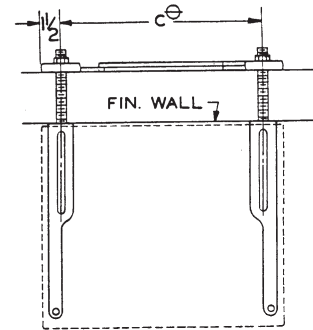
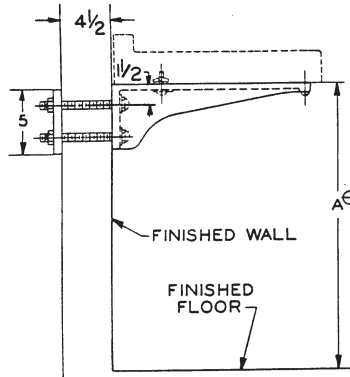

⊖ VARIABLE – DEPENDS ON FIXTURE.

17 LBS

17390-BP SERIES

WALL-MOUNT with -BP Back Plates

APPLICATION

For use with lavatories designed for heavy-duty exposed arms where wall construction will support the fixture and carrier assembly.

SPECIFICATION

JOSAM 17390-BP Series wall-mounted, single Lavatory Carrier with exposed acid-resisting white coated arms, leveling and securing screws, adjustable wall plate, back plates and chrome-plated trim.

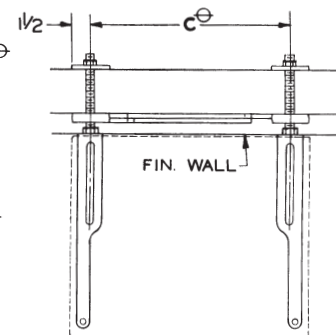
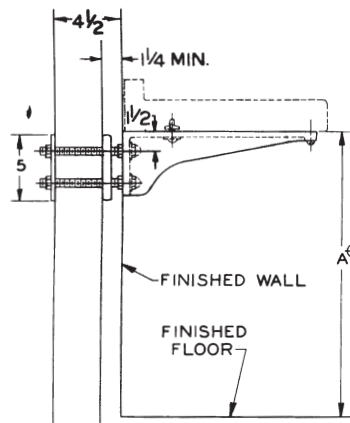

⊖ VARIABLE – DEPENDS ON FIXTURE.

19 LBS